

Inter-IC Sound Bus (I2S)

2.30

Features

- Master only
- 8 to 32 data bits per sample
- 16-, 32-, 48-, or 64-bit word select period
- Data rate up to 96 kHz with 64-bit word select period: 6.144 MHz
- Tx and Rx FIFO interrupts
- DMA support
- Independent left and right channel FIFOs or interleaved stereo FIFOs
- Independent enable of Rx and Tx

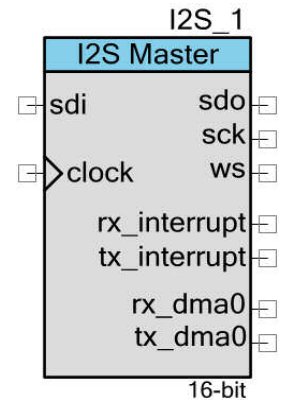

General Description

The Integrated Inter-IC Sound Bus (I2S) is a serial bus interface standard used for connecting digital audio devices together. The specification is from Philips[®] Semiconductor (I2S bus specification; February 1986, revised June 5, 1996).

The I2S component operates in master mode only. It also operates in two directions, as a transmitter (Tx) and a receiver (Rx). The data for Tx and Rx are independent byte streams. The byte streams are packed with the most significant byte first and the most significant bit in bit 7 of the first word. The number of bytes used for each sample (a sample for the left or right channel) is the minimum number of bytes to hold a sample.

When to Use an I2S

The component provides a serial bus interface for stereo audio data. This interface is most commonly used by audio ADC and DAC components.

Input/Output Connections

This section describes the various input and output connections for the I2S component. An asterisk (*) in the list of I/Os indicates that the I/O may be hidden on the symbol under the conditions listed in the description of that I/O.

sdi – Input *

Serial data input. Displays if an Rx option is selected for the **Direction** parameter.

If this signal is connected to an input pin, then the "Input Synchronized" selection for this pin should be disabled. This signal should already be synchronized to SCK, so delaying the signal with the input pin synchronizer could cause the signal to be shifted into the next clock cycle.

clock – Input

The clock rate provided must be two times the desired clock rate for the output serial clock (SCK). For example, to produce 48-kHz audio with a 64-bit word select period the clock frequency is:

$$2 \times 48 \text{ kHz} \times 64 = 6.144 \text{ MHz}$$

sdo – Output *

Serial data output. Displays if a Tx option is selected for the **Direction** parameter.

sck – Output

Output serial clock.

ws – Output

Word select output indicates the channel being transmitted.

rx_interrupt – Output *

Rx direction interrupt. Displays if an Rx option is selected for the **Direction** parameter.

tx_interrupt – Output *

Tx direction interrupt. Displays if a Tx option is selected for the **Direction** parameter.

rx_DMA0 – Output *

Rx direction DMA request for FIFO 0 (Left or Interleaved). Displays if a **Rx DMA** is selected under the **DMA Request** parameter.



rx_DMA1 – Output *

Rx direction DMA request for FIFO 1 (Right). Displays if a **Rx DMA** is selected under the **DMA Request** parameter and **Separated L/R** under the **Data Interleaving** parameter for Rx.

tx_DMA0– Output *

Tx direction DMA request for FIFO 0 (Left or Interleaved). Displays if a **Tx DMA** is selected under the **DMA Request** parameter.

tx_DMA1 – Output *

Tx direction DMA request for FIFO 1 (Right). Displays if a **Tx DMA** is selected under the **DMA Request** parameter and **Separated L/R** under the **Data Interleaving** parameter for Tx.

Schematic Macro Information

By default, the PSoC Creator Component Catalog contains three Schematic Macro implementations for the I2S component. These macros contain the I2S component already connected to digital pin components. The “Input Synchronized” option is unchecked on the SDI pin, and the generation of APIs for all of the pins is turned off. The Schematic Macros use the I2S component configured for Rx only, Tx only, and both Rx and Tx directions, as shown in the following diagrams.

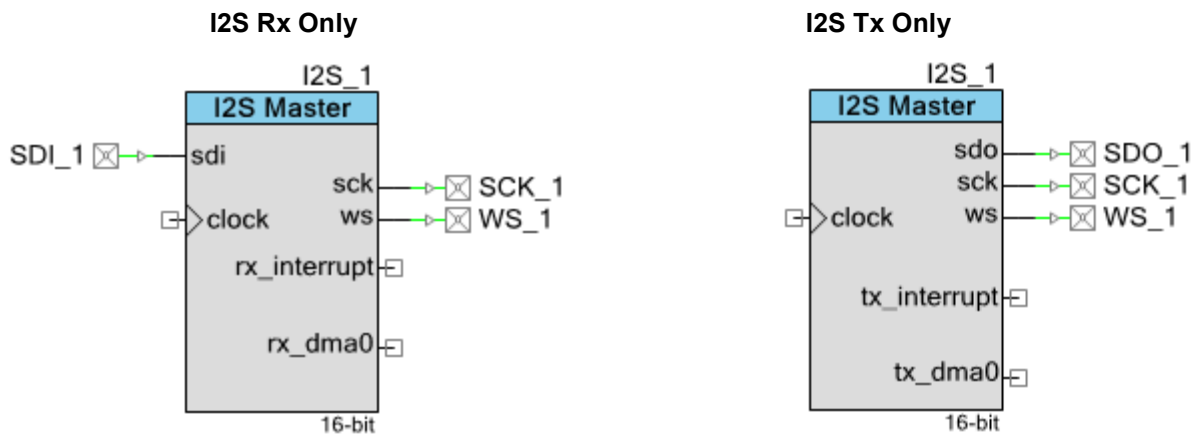

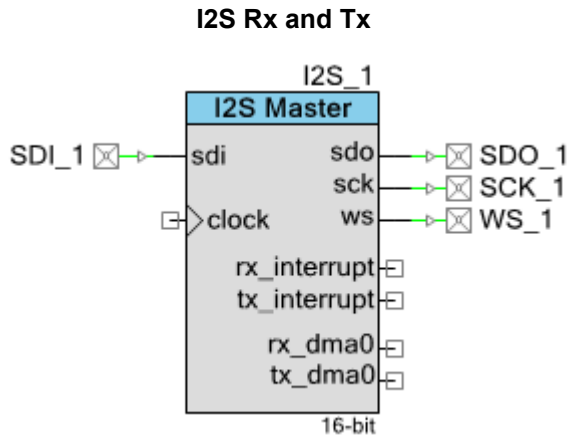

Component Parameters

Drag an I2S component onto your design and double-click it to open the **Configure** dialog. This dialog has two tabs used for the process of setting up the I2S component.

Figure 1. Basic Tab

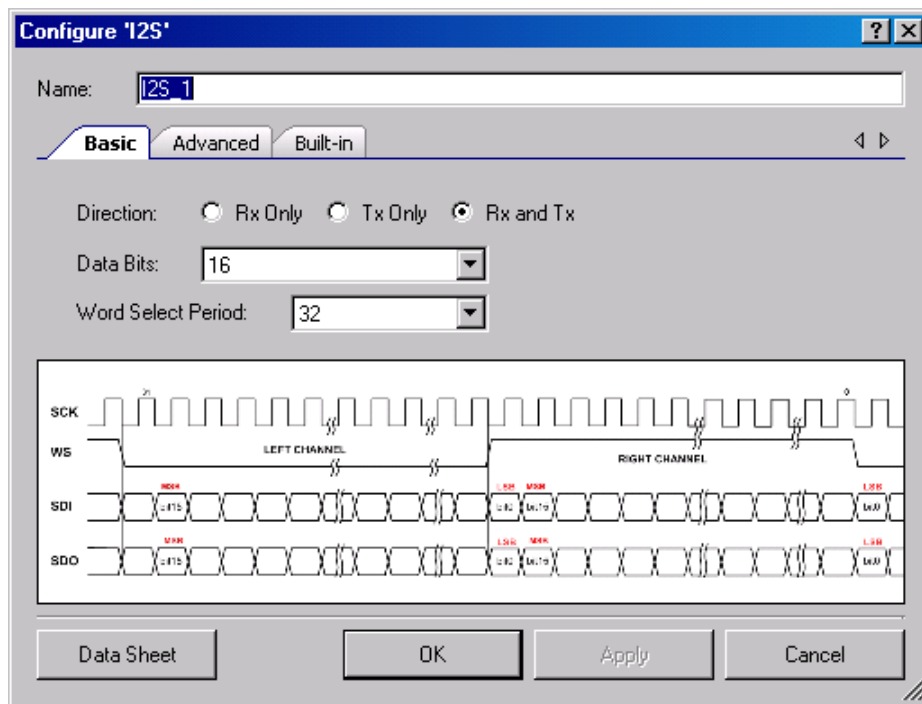

Direction

Determines which direction the component operates. This value can be set to **Rx Only**, **Tx Only**, or **Rx and Tx** (default).

Data Bits

Determines the number of data bits configured for each sample (hardware compiled). This value can be set between 8 and 32. The default setting is **16**.

Word Select Period

Defines the period of a complete sample of both left and right channels. This value can be set to **16, 32 (default), 48, or 64**.

Figure 2. Advanced Tab

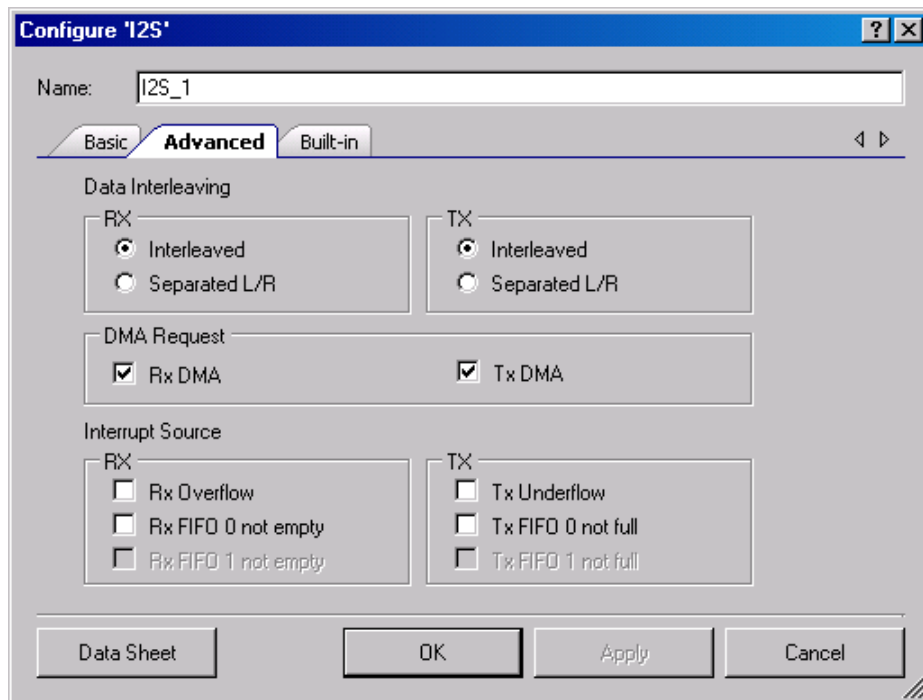

Data Interleaving

Used to select whether the data is **Interleaved** (default) or **Separate L/R**. Rx and Tx are selected independently.

DMA Request

Used to enable and disable the DMA request signals for the component. Rx and Tx are selected independently. These options are **enabled** by default.

Interrupt Source

Used to configure the interrupt sources for Rx and Tx direction. Rx and Tx directions have separate interrupt outputs. Multiple sources for each direction are ORed together. The software



can re-configure these sources at any time; these parameters simply define an initial configuration. Settings include:

- Rx:
 - Rx Overflow**
 - Rx FIFO 0 not empty** (Left or Interleaved)
 - Rx FIFO 1 not empty** (Right) - Only an option if not Interleaved
- Tx:
 - Tx Underflow**
 - Tx FIFO 0 not full** (Left or Interleaved)
 - Tx FIFO 1 not full** (Right) - Only an option if not Interleaved

Clock Selection

There is no internal clock in this component. You must attach a clock source. The clock rate provided must be two times the desired clock rate for the output serial clock (SCK).

Application Programming Interface

Application Programming Interface (API) routines allow configuration of the component using the software. The following table lists and describes the interface for each function. The subsequent sections cover each function in more detail.

By default, PSoC Creator assigns the instance name “I2S_1” to the first instance of a component in a given design. The instance can be renamed to any unique value that follows the syntactic rules for identifiers. The instance name becomes the prefix of every global function name, variable, and constant symbol. For readability, the instance name used in the following table is “I2S.”

Function	Description
I2S_Start()	Starts the I2S interface
I2S_Stop()	Disables the I2S interface
I2S_EnableTx()	Enables the Tx direction of the I2S interface
I2S_DisableTx()	Disables the Tx direction of the I2S interface
I2S_EnableRx()	Enables the Rx direction of the I2S interface
I2S_DisableRx()	Disables the Rx direction of the I2S interface
I2S_SetRxInterruptMode()	Sets the interrupt source for the I2S Rx direction interrupt
I2S_SetTxInterruptMode()	Sets the interrupt source for the I2S Tx direction interrupt

Function	Description
I2S_ReadRxStatus()	Returns state in the I2S Rx status register
I2S_ReadTxStatus()	Returns state in the I2S Tx status register
I2S_ReadByte()	Returns a single byte from the Rx FIFO
I2S_WriteByte()	Writes a single byte into the Tx FIFO
I2S_ClearRxFIFO()	Clears out the Rx FIFO
I2S_ClearTxFIFO()	Clears out the Tx FIFO
I2S_Sleep()	Saves configuration and disables the I2S interface
I2S_Wakeup()	Restores configuration and enables the I2S interface
I2S_Init()	Enables the I2S interface
I2S_Enable()	Initializes or restores default I2S configuration
I2S_SaveConfig()	Saves configuration of I2S interface
I2S_RestoreConfig()	Restores configuration of I2S interface

Global Variables

Variable	Description
I2S_initVar	Indicates whether the I2S has been initialized. The variable is initialized to 0 and set to 1 the first time I2S_Start() is called. This allows the component to restart without reinitialization after the first call to the I2S_Start() routine. If reinitialization of the component is required, call I2S_Init() before calling I2S_Start(). Alternatively, the I2S can be reinitialized by calling the I2S_Init() and I2S_Enable() functions.

void I2S_Start(void)

Description: Starts the I2S interface. Enables Active mode power template bits or clock gating as appropriate. Starts the generation of the sck and ws outputs. The Tx and Rx directions remain disabled.

Parameters: None

Return Value: None

Side Effects: None



void I2S_Stop(void)

Description: Disables the I2S interface. Disables Active mode power template bits or clock gating as appropriate. The sck and ws outputs are set to 0. The Tx and Rx directions are disabled and their FIFOs are cleared.

Parameters: None

Return Value: None

Side Effects: None

void I2S_EnableTx(void)

Description: Enables the Tx direction of the I2S interface. Transmission begins at the next word select falling edge.

Parameters: None

Return Value: None

Side Effects: None

void I2S_DisableTx(void)

Description: Disables the Tx direction of the I2S interface. Transmission of data stops and a constant 0 value is transmitted at the next word select falling edge.

Parameters: None

Return Value: None

Side Effects: None

void I2S_EnableRx(void)

Description: Enables the Rx direction of the I2S interface. Data reception begins at the next word select falling edge.

Parameters: None

Return Value: None

Side Effects: None



void I2S_DisableRx(void)

- Description:** Disables the Rx direction of the I2S interface. At the next word select falling edge, data reception is no longer sent to the receive FIFO.
- Parameters:** None
- Return Value:** None
- Side Effects:** None

void I2S_SetRxInterruptMode(uint8 interruptSource)

- Description:** Sets the interrupt source for the I2S Rx direction interrupt. Multiple sources may be ORed.
- Parameters:** uint8: Byte containing the constant for the selected interrupt sources

I2S Rx Interrupt Source	Value	Type
RX_FIFO_OVERFLOW	0x01	Clear on Read
RX_FIFO_0_NOT_EMPTY	0x02	Transparent
RX_FIFO_1_NOT_EMPTY	0x04	Transparent

- Return Value:** None
- Side Effects:** If clear on read bits are used as the sources for the interrupt generation the rx_interrupt output remains asserted until the I2S Rx status register is read.

void I2S_SetTxInterruptMode(uint8 interruptSource)

- Description:** Sets the interrupt source for the I2S Tx direction interrupt. Multiple sources may be ORed.
- Parameters:** uint8: Byte containing the constant for the selected interrupt sources

I2S Tx Interrupt Source	Value	Type
TX_FIFO_UNDERFLOW	0x01	Clear on Read
TX_FIFO_0_NOT_FULL	0x02	Transparent
TX_FIFO_1_NOT_FULL	0x04	Transparent

- Return Value:** None
- Side Effects:** If clear on read bits are used as the sources for the interrupt generation, the tx_interrupt output remains asserted until the I2S Tx status register is read.



uint8 I2S_ReadRxStatus(void)**Description:** Returns state of the I2S Rx status register.**Parameters:** None**Return Value:** uint8: State of the I2S Rx status register

I2S Rx Status Masks	Value	Type
RX_FIFO_OVERFLOW	0x01	Clear on Read
RX_FIFO_0_NOT_EMPTY	0x02	Transparent
RX_FIFO_1_NOT_EMPTY	0x04	Transparent

Side Effects: Clears the bits of the I2S Rx status register that are clear on read.**uint8 I2S_ReadTxStatus(void)****Description:** Returns state of the I2S Tx status register.**Parameters:** None**Return Value:** uint8: State of the I2S Tx status register

I2S Tx Status Masks	Value	Type
TX_FIFO_UNDERFLOW	0x01	Clear on Read
TX_FIFO_0_NOT_FULL	0x02	Transparent
TX_FIFO_1_NOT_FULL	0x04	Transparent

Side Effects: Clears the bits of the I2S Rx status register that are clear on read.**uint8 I2S_ReadByte(uint8 wordSelect)****Description:** Returns a single byte from the Rx FIFO. Check the Rx status before this call to confirm that the Rx FIFO is not empty.**Parameters:** uint8: Indicates to read from the Left (0) or Right (1) channel. In interleaved mode, this parameter is ignored.**Return Value:** uint8: Byte containing the data received**Side Effects:** None

void I2S_WriteByte(uint8 wrData, uint8 wordSelect)

- Description:** Writes a single byte into the Tx FIFO. Check the Tx status before this call to confirm that the Tx FIFO is not full.
- Parameters:** uint8 wrData: Byte containing the data to transmit
uint8 wordSelect: Indicates to write to the Left (0) or Right (1) channel. In interleaved mode, this parameter is ignored
- Return Value:** None
- Side Effects:** None

void I2S_ClearRxFIFO(void)

- Description:** Clears out the Rx FIFO. Any data present in the FIFO is lost. Call this function only when the Rx direction is disabled.
- Parameters:** None
- Return Value:** None
- Side Effects:** None

void I2S_ClearTxFIFO(void)

- Description:** Clears out the Tx FIFO. Any data present in the FIFO is lost. Call this function only when the Tx direction is disabled.
- Parameters:** None
- Return Value:** None
- Side Effects:** None

void I2S_Sleep(void)

- Description:** This is the preferred routine to prepare the component for sleep. The I2S_Sleep() routine saves the current component state. Then it calls the I2S_Stop() function and calls I2S_SaveConfig() to save the hardware configuration. Disables Active mode power template bits or clock gating as appropriate. The sck and ws outputs are set to 0. The Tx and Rx directions are disabled.
- Call the I2S_Sleep() function before calling the CyPmSleep() or the CyPmHibernate() function. Refer to the PSoC Creator *System Reference Guide* for more information about power management functions.
- Parameters:** None
- Return Value:** None
- Side Effects:** None



void I2S_Wakeup(void)

- Description:** Restores I2S configuration and nonretention register values. Enables Active mode power template bits or clock gating, as appropriate. Starts the generation of the sck and ws outputs. Enables Rx and/or Tx direction according to their states before sleep.
- Parameters:** None
- Return Value:** None
- Side Effects:** Calling the I2S_Wakeup() function without first calling the I2S_Sleep() or I2S_SaveConfig() function may produce unexpected behavior.

void I2S_Init(void)

- Description:** Initializes or restores default I2S configuration provided with customizer that defines interrupt sources for the component.
- Parameters:** None
- Return Value:** None
- Side Effects:** Restores only mask registers for interrupt generation. It does not clear data from the FIFOs and does not reset component hardware state machines.

void I2S_Enable(void)

- Description:** Activates the hardware and begins component operation. It is not necessary to call I2S_Enable() because the I2S_Start() routine calls this function, which is the preferred method to begin component operation.
- Parameters:** None
- Return Value:** None
- Side Effects:** None

void I2S_SaveConfig(void)

- Description:** This function saves the component configuration and nonretention registers. It also saves the current component parameter values, as defined in the Configure dialog or as modified by appropriate APIs. This function is called by the I2S_Sleep() function.
- Parameters:** None
- Return Value:** None
- Side Effects:** None



void I2S_RestoreConfig(void)

- Description:** This function restores the component configuration and nonretention registers. It also restores the component parameter values to what they were prior to calling the I2S_Sleep() function. This routine is called by I2S_Wakeup() to restore the component when it exits sleep.
- Parameters:** None
- Return Value:** None
- Side Effects:** Must be called only after I2S_SaveConfig() routine. Otherwise, the component configuration will be overwritten with its initial setting.

Sample Firmware Source Code

PSoC Creator provides numerous example projects that include schematics and example code in the Find Example Project dialog. For component-specific examples, open the dialog from the Component Catalog or an instance of the component in a schematic. For general examples, open the dialog from the Start Page or **File** menu. As needed, use the **Filter Options** in the dialog to narrow the list of projects available to select.

Refer to the “Find Example Project” topic in the PSoC Creator Help for more information.

Functional Description

Left/Right and Rx/Tx Configuration

The configuration for the Left and Right channels – the Rx and Tx direction, number of bits, and word-select period – are identical. If the application must have different configurations for the Rx and Tx, then use two unidirectional component instances.

Data Stream Format

The data for Tx and Rx is independent byte streams. The byte streams are packed with the most significant byte first and the most significant bit in bit 7 of the first word. The number of bytes used for each sample (for the left or right channel) is the minimum number of bytes to hold a sample. Any unused bits are ignored on Tx and are 0 on Rx.

The data stream for one direction can be a single byte stream, or it can be two byte streams. In the case of a single byte stream, the left and right channels are interleaved with a sample for the left channel first followed by the right channel. In the two-stream case, the left and right channel byte streams use separate FIFOs.

DMA

The I2S interface is a continuous interface that requires an uninterrupted stream of data. For most applications, this requires the use of DMA transfers to prevent the underflow of the Tx direction or the overflow of the Rx direction.



The I2S can drive up to two DMA components for each direction. Use the DMA Wizard to configure DMA operation as follows:

Name of DMA Source/ Destination in the DMA Wizard	Direction	DMA Request Signal	DMA Request Type	Description
I2S_RX_FIFO_0_PTR	Source	rx_dma0	Level	Receive FIFO for Left or Interleaved channel
I2S_RX_FIFO_1_PTR	Source	rx_dma1	Level	Receive FIFO for Right channel
I2S_TX_FIFO_0_PTR	Destination	tx_dma0	Level	Transmit FIFO for Left or Interleaved channel
I2S_TX_FIFO_1_PTR	Destination	tx_dma1	Level	Transmit FIFO for Right channel

In all cases, a high signal on the DMA request signal indicates that an additional single byte may be transferred.

Enabling

The Rx and Tx directions have separate enables. When not enabled, the Tx direction transmits all 0 values, and the Rx direction ignores all received data. The transition into and out of the enabled state occurs at a word select boundary such that a left/right sample pair is always transmitted or received.

Error Handling

Two error conditions for the component can occur if the transmit FIFO is empty and a subsequent read occurs (transmit underflow), or if the receive FIFO is full and a subsequent write occurs (receive overflow).

While transmission is enabled, if the transmit FIFO becomes empty and data is not available for transmission (Transmit underflow), the component forces the constant transmission of 0s. Before transmission begins again, transmission must be disabled, the FIFOs should be cleared, data for transmit must be buffered, and then transmission re-enabled. The CPU can monitor this underflow condition using the transmit status bit I2S_TX_FIFO_UNDERFLOW. An interrupt can also be configured for this error condition.

While reception is enabled, if the receive FIFO becomes full and additional data is received (Receive overflow), the component stops capturing data. Before reception begins again, reception must be disabled, the FIFOs should be cleared, and then reception re-enabled. The CPU can monitor this overflow condition using the receive status bit I2S_RX_FIFO_OVERFLOW. An interrupt can also be configured for this error condition.

Block Diagram and Configuration

The I2S is implemented as a set of configured UDBs. The implementation is shown in the following block diagram.

Figure 3. I2S Implementation

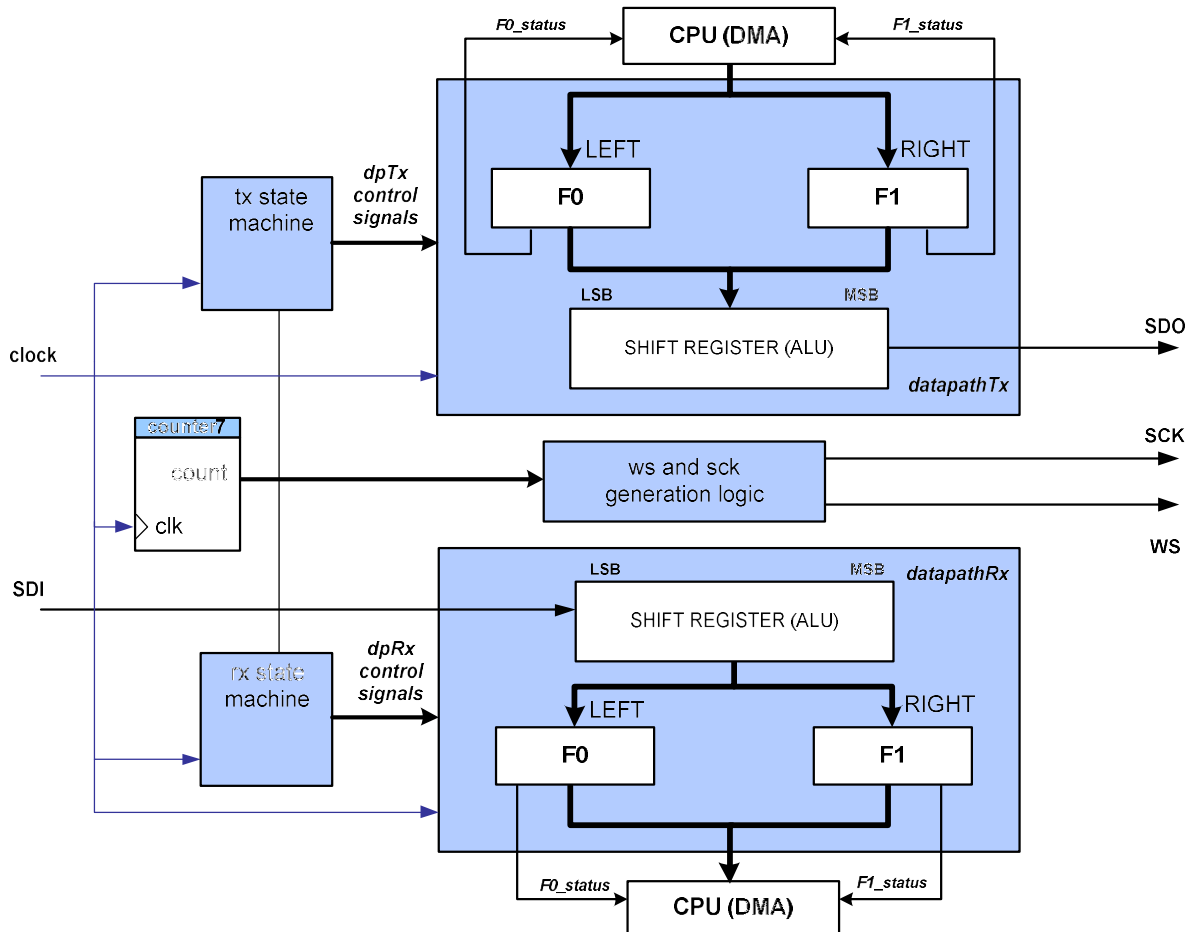

Registers

I2S_CONTROL_REG

Bits	7	6	5	4	3	2	1	0
Value	reserved					enable	rxenable	txenable

- enable: Enable/Disable I2S component
- rxenable, txenable: Enable/Disable Rx and Tx directions, respectively



I2S_TX_STATUS_REG

Bits	7	6	5	4	3	2	1	0
Value	reserved					F1_not_full	F0_not_full	underflow

- F1_not_full: If set, Tx FIFO 1 is not full
- F0_not_full: If set, Tx FIFO 0 is not full
- underflow: If set, Tx FIFOs underflow event has occurred

The register value can be read with the I2S_ReadTxStatus() API function.

I2S_RX_STATUS_REG

Bits	7	6	5	4	3	2	1	0
Value	reserved					F1_not_empty	F0_not_empty	overflow

- F1_not_empty: If set, Rx FIFO 1 is not empty
- F0_not_empty: If set, Rx FIFO 0 is not empty
- overflow: If set, Rx FIFOs overflow event has occurred

The register value can be read with the I2S_ReadRxStatus() API function.

Note: Bit 0 (underflow) of the Tx status register and bit 0 (overflow) of the Rx status register are configured as clear on read bits. In this mode, the input status is sampled after each cycle of the status register clock. When the input goes high, the register bit is set and stays set regardless of the subsequent state of the input. The register bit is cleared on a subsequent read by the CPU.

Resources

The I2S component is placed throughout the UDB array. The component utilizes the following resources.

Configuration	Resource Type					
	Datapath Cells	Macrocells	Status Cells	Control Cells	DMA Channels	Interrupts
Rx Only	1	7	1	2	–	–
Tx Only	1	8	1	2	–	–
Rx and Tx	2	13	2	4	–	–

API Memory Usage

The component memory usage varies significantly depending on the compiler, device, number of APIs used and component configuration. The following table provides the memory usage for all APIs available in the given component configuration.

The measurements have been done with an associated compiler configured in Release mode with optimization set for Size. For a specific design, the map file generated by the compiler can be analyzed to determine the memory usage.

Configuration	PSoC 3 (Keil_PK51)		PSoC 5 (GCC)		PSoC 5LP (GCC)	
	Flash Bytes	SRAM Bytes	Flash Bytes	SRAM Bytes	Flash Bytes	SRAM Bytes
Rx Only	220	3	442	5	392	5
Tx Only	220	3	442	5	592	5
Rx and Tx	326	3	658	9	592	5

DC and AC Electrical Characteristics

Specifications are valid for $-40\text{ }^{\circ}\text{C} \leq T_A \leq 85\text{ }^{\circ}\text{C}$ and $T_J \leq 100\text{ }^{\circ}\text{C}$, except where noted.
Specifications are valid for 1.71 V to 5.5 V, except where noted.

DC Characteristics

Parameter	Description	Min	Typ ^[1]	Max	Units ^[2]
$I_{DD(RX)}$	Component current consumption (Rx Only)				
	Idle current ^[3]	–	15	–	$\mu\text{A}/\text{MHz}$
	Operating current ^[4]	–	21	–	$\mu\text{A}/\text{MHz}$
$I_{DD(TX)}$	Component current consumption (Tx Only)				
	Idle current ^[3]	–	15	–	$\mu\text{A}/\text{MHz}$
	Operating current ^[4]	–	20	–	$\mu\text{A}/\text{MHz}$

1. Device IO and clock distribution current are not included. The values are at 25 °C.
2. Current consumption is specified with respect to the incoming component clock.
3. Current consumed by component while it is enabled but not transmitting/receiving data.
4. Current consumed by component while it is enabled and transmitting/receiving data.



Parameter	Description	Min	Typ ^[1]	Max	Units ^[2]
I _{DD(RX_TX)}	Component current consumption (Rx and Tx)				
	Idle current ^[3]	–	16	–	μA/MHz
	Operating current ^[4]	–	26	–	μA/MHz

AC Characteristics

Parameter	Description	Min	Typ	Max	Unit
f _{SCK}	Serial clock (output) frequency	–	–	6.144	MHz
f _{CLOCK} ^[5]	Component clock frequency	–	2 × f _{SCK}	–	MHz
t _{SCKH}	SCK high-level time	–	0.5	–	1/f _{SCLK}
t _{SCKL}	SCK low-level time	–	0.5	–	1/f _{SCLK}
t _{SCK_WS}	Delay time, SCK falling edge to WS valid	–20	–	20	ns
t _{SCK_SDO}	Delay time, SCK falling edge to SDO valid	–20	–	20	ns
t _{S_SDI} ^[6]	SDI setup time	25	–	–	ns

Component Clock Rates for Common Audio Sampling Frequencies

Sampling Frequency	Component Clock Frequency (f _{CLOCK}) MHz			
	t _{WS} = 16 bits	t _{WS} = 32 bits	t _{WS} = 48 bits	t _{WS} = 64 bits
8 kHz	0.2560	0.5120	0.7680	1.0240
16 kHz	0.5120	1.0240	1.5360	2.0480
32 kHz	1.0240	2.0480	3.0720	4.0960
44.1 kHz	1.4112	2.8224	4.2336	5.6448
48 kHz	1.5360	3.0720	4.6080	6.1440
88.2 kHz	2.8224	5.6448	8.4672	11.2896
96 kHz	3.0720	6.1440	9.2160	12.2880
192 kHz	6.1440	12.2880	N/A	N/A

5. The maximum component clock frequency is derived from t_{CLK_SCK} in combination with the routing path delays of the SCK output and the SDI input (described later in this document). Typical values provide a maximum safe operating frequency of the component. The component can run at higher clock frequencies, at which point validation of the timing requirements with STA results is necessary.

6. The V_{DDIO} supply voltage from 3.0 V to 5.5 V. The value can vary for PSoC 5, so must be validated with STA results.



Figure 4. Data Transition Timing Diagram

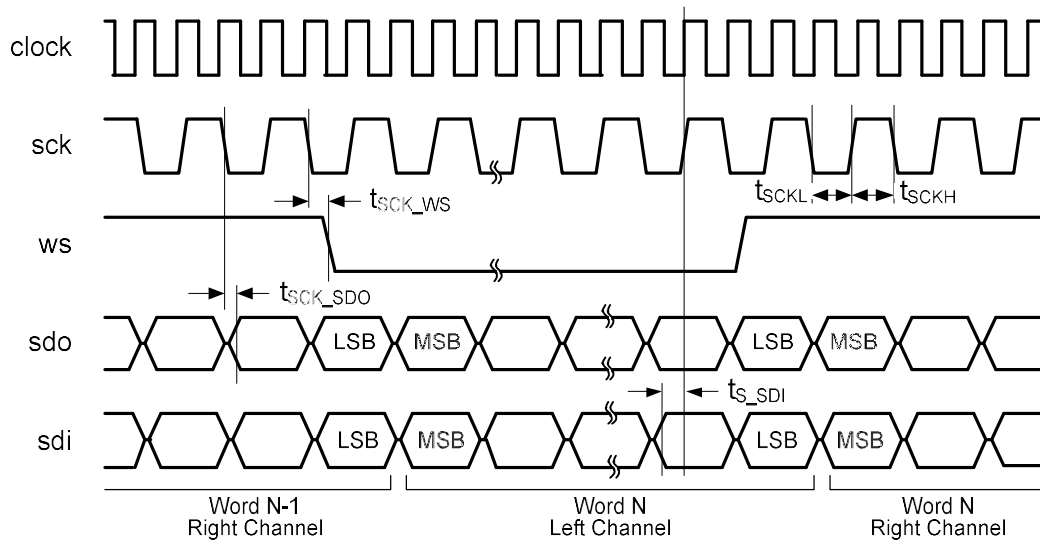

Note All of the component internal logic operates entirely from the input 2X clock. This causes the need to reference some timing constraints, such as t_{S_SDI} and t_{CLK_SCK} , with respect to this internal clock (described later in this document).

How to Use STA results for Characteristics Data

f_{SCK} The maximum frequency of SCK (or the maximum bit rate) is not provided directly in the STA. However, the data provided in the STA results indicates some of the internal logic timing constraints. To calculate the maximum bit rate, several factors must be considered. Board layout and slave communication device specs are needed to fully understand the maximum. A limiting factor in this parameter is the round trip path delay from the falling edge of SCK at the pin of the master to the slave, and the path delay of the SDO output of the slave back to the SDI input of the master. In this case, the component must meet the setup time of SDI at the master with the following equation:



Figure 5. Calculating Maximum f_{SCK} Frequency

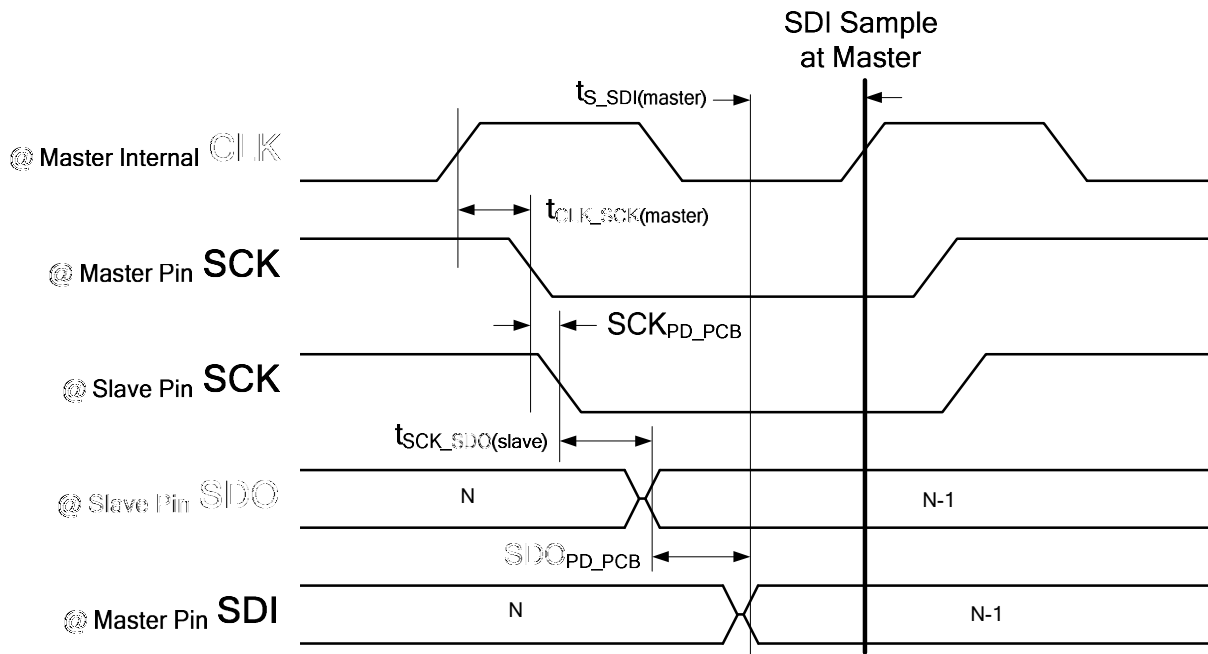

In this case, the f_{SCK} frequency is calculated using the equation below:

$$f_{SCK} < 1 \div [2 \times [t_{RT_PD} + t_{CLK_SCK(master)} + t_{S_SDI(master)}]]$$

Where

$$t_{RT_PD} = [SCK_{PD_PCB} + t_{SCK_SDO(slave)} + SDO_{PD_PCB}]$$

and,

SCK_{PD_PCB} is the PCB path delay of SCK from the pin of the master component to the pin of the slave device.

$t_{SCK_SDO(slave)}$ comes from the Slave Device datasheet

$t_{CLK_SCK(master)}$ is the internal CLK to SCK pin path delay of the master component. This is provided in the STA results clock to output section, as shown below:

- Clock To Output Section

- CLK

Source	Destination	Delay (ns)
I2S:BitCounter\count_0	SCK(0)_PAD	24.484
Net_5/q	SDO(0)_PAD	23.808
Net_4/q	WS(0)_PAD	22.958

$t_{S_SDI(master)}$ is the SDI pin to the internal logic path delay of the master component. This is provided in the STA results input to clock section, as shown below:



- Input To Clock Section

- CLK

Source	Destination	Delay (ns)
SDI(0)_PAD	\I2S:Rx:dpRx:u0\route_si	19.977

The final equation that provides the maximum frequency of SCK follows; the maximum bit rate is:

$$f_{SCK}(\text{Max.}) = 1 \div [2 \times [t_{CLK_SCK(\text{master})} + SCK_{PD_PCB} + t_{SCK_SDO(\text{slave})} + SDO_{PD_PCB} + t_{S_SDI(\text{master})}]]$$

f_{CLK} Maximum component clock frequency is provided in Timing results in the clock summary as the named external clock (CLK in this case). An example of the internal clock limitations from the STA report follows:

+ Clock Summary Section

Clock	Type	Nominal Frequency (MHz)	Required Frequency (MHz)	Maximum Frequency (MHz)	Violation
BUS_CLK	Sync	24.000	24.000	N/A	
CLK	Sync	6.000	6.000	65.398	
ClockBlock/clk_bus	Async	24.000	24.000	N/A	
ClockBlock/dclk_0	Async	6.000	6.000	N/A	
ILO	Async	0.001	0.001	N/A	
IMO	Async	3.000	3.000	N/A	
MASTER_CLK	Sync	24.000	24.000	N/A	
PLL_OUT	Async	24.000	24.000	N/A	

t_{SCKH} The I2S component generates a 50-percent duty cycle SCK

t_{SCKL} The I2S component generates a 50-percent duty cycle SCK

t_{SCK_ws} The delay between SCK falling edge and WS valid. This value can be calculated as the difference between clock to output times for WS and SCK pins. The data is extracted from the STA report, as shown below:

- Clock To Output Section

- CLK

Source	Destination	Delay (ns)
\I2S:BitCounter\count_0	SCK(0)_PAD	24.484
Net_5/q	SDO(0)_PAD	23.808
Net_4/q	WS(0)_PAD	22.958

t_{SCK_sdo} The delay between SCK falling edge and WS valid. This value can be calculated as the difference between clock to output times for SDO and SCK pins. The values are provided in the STA results clock to output times, as shown below:

- Clock To Output Section

- CLK

Source	Destination	Delay (ns)
\I2S:BitCounter\count_0	SCK(0)_PAD	24.484
Net_5/q	SDO(0)_PAD	23.808
Net_4/q	WS(0)_PAD	22.958



t_{s_SDI} SDI setup time is the SDI pin to internal logic path delay of the master component. This is provided in the STA results Input to Clock Section, as shown below:

- Input To Clock Section

- CLK

Source	Destination	Delay (ns)
SDI(0)_PAD	\I2S:Rx:dpRx:u0\route_si	19.977

Component Changes

This section lists the major changes in the component from the previous version.

Version	Description of Changes	Reason for Changes / Impact
2.30	Added all component APIs with the CYREENTRANT keyword when they are included in the .cyre file.	Not all APIs are truly reentrant. Comments in the component API source files indicate which functions are candidates. This change is required to eliminate compiler warnings for functions that are not reentrant used in a safe way: protected from concurrent calls by flags or Critical Sections.
	Added PSoC 5LP support	
	Added DC characteristics section to datasheet	
2.20	Added internal FIFO error detection by the component.	Improved error handling by the component in case of an overflow/underflow error occurs.
2.10	Resampled FIFO block status signals to DP clock.	Allows component to function with the same timing results for all PSoC 3 and PSoC 5 silicons.
	Added characterization data to datasheet	
	Minor datasheet edits and updates	
2.0	Hardware implementation of this component was changed to require a 2X frequency signal on the clock input. The SCK output signal will be generated by dividing the incoming clock by 2.	Improves the control of the timing relationship between the SCK, WS, SDO and SDI signals.
	I2S_Start() function updated to match changes in the implementation. The functionality is unchanged.	Simplified implementation required changes to the initialization.
	The sleep mode APIs were added.	To support low-power modes.

Version	Description of Changes	Reason for Changes / Impact
	The status bits tx_not_full and rx_not_emty were changed from clear-on-read to transparent mode.	The status bits for any Full or Empty status from a FIFO need to be transparent to represent just the current live status of the FIFO.
	Added DMA Capabilities file to the component.	This file allows I2S to be supported by the DMA Wizard tool in PSoC Creator.
	I2S_Stop() API was changed to clear rx and tx FIFOs after component is disabled.	Resets the Tx and Rx FIFOs status to the initial values. Prevents unexpected operations after component is re-enabled.
	Added Keil function reentrancy support.	Add the capability for customers to specify individual generated functions as reentrant.

© Cypress Semiconductor Corporation, 2012. The information contained herein is subject to change without notice. Cypress Semiconductor Corporation assumes no responsibility for the use of any circuitry other than circuitry embodied in a Cypress product. Nor does it convey or imply any license under patent or other rights. Cypress products are not warranted nor intended to be used for medical, life support, life saving, critical control or safety applications, unless pursuant to an express written agreement with Cypress. Furthermore, Cypress does not authorize its products for use as critical components in life-support systems where a malfunction or failure may reasonably be expected to result in significant injury to the user. The inclusion of Cypress products in life-support systems application implies that the manufacturer assumes all risk of such use and in doing so indemnifies Cypress against all charges.

PSoC® is a registered trademark, and PSoC Creator™ and Programmable System-on-Chip™ are trademarks and of Cypress Semiconductor Corp. All other trademarks or registered trademarks referenced herein are property of the respective corporations.

Any Source Code (software and/or firmware) is owned by Cypress Semiconductor Corporation (Cypress) and is protected by and subject to worldwide patent protection (United States and foreign), United States copyright laws and international treaty provisions. Cypress hereby grants to licensee a personal, non-exclusive, non-transferable license to copy, use, modify, create derivative works of, and compile the Cypress Source Code and derivative works for the sole purpose of creating custom software and or firmware in support of licensee product to be used only in conjunction with a Cypress integrated circuit as specified in the applicable agreement. Any reproduction, modification, translation, compilation, or representation of this Source Code except as specified above is prohibited without the express written permission of Cypress.

Disclaimer: CYPRESS MAKES NO WARRANTY OF ANY KIND, EXPRESS OR IMPLIED, WITH REGARD TO THIS MATERIAL, INCLUDING, BUT NOT LIMITED TO, THE IMPLIED WARRANTIES OF MERCHANTABILITY AND FITNESS FOR A PARTICULAR PURPOSE. Cypress reserves the right to make changes without further notice to the materials described herein. Cypress does not assume any liability arising out of the application or use of any product or circuit described herein. Cypress does not authorize its products for use as critical components in life-support systems where a malfunction or failure may reasonably be expected to result in significant injury to the user. The inclusion of Cypress' product in a life-support systems application implies that the manufacturer assumes all risk of such use and in doing so indemnifies Cypress against all charges.

Use may be limited by and subject to the applicable Cypress software license agreement.

