



# FM3 Family MB9A310K/110K Series, Flash Programming Guide

Doc. No. 002-04787 Rev. \*B

Cypress Semiconductor  
198 Champion Court  
San Jose, CA 95134-1709  
<http://www.cypress.com>

## Copyrights

© Cypress Semiconductor Corporation, 2012-2017. This document is the property of Cypress Semiconductor Corporation and its subsidiaries, including Spansion LLC (“Cypress”). This document, including any software or firmware included or referenced in this document (“Software”), is owned by Cypress under the intellectual property laws and treaties of the United States and other countries worldwide. Cypress reserves all rights under such laws and treaties and does not, except as specifically stated in this paragraph, grant any license under its patents, copyrights, trademarks, or other intellectual property rights. If the Software is not accompanied by a license agreement and you do not otherwise have a written agreement with Cypress governing the use of the Software, then Cypress hereby grants you a personal, non-exclusive, nontransferable license (without the right to sublicense) (1) under its copyright rights in the Software (a) for Software provided in source code form, to modify and reproduce the Software solely for use with Cypress hardware products, only internally within your organization, and (b) to distribute the Software in binary code form externally to end users (either directly or indirectly through resellers and distributors), solely for use on Cypress hardware product units, and (2) under those claims of Cypress’s patents that are infringed by the Software (as provided by Cypress, unmodified) to make, use, distribute, and import the Software solely for use with Cypress hardware products. Any other use, reproduction, modification, translation, or compilation of the Software is prohibited.

TO THE EXTENT PERMITTED BY APPLICABLE LAW, CYPRESS MAKES NO WARRANTY OF ANY KIND, EXPRESS OR IMPLIED, WITH REGARD TO THIS DOCUMENT OR ANY SOFTWARE OR ACCOMPANYING HARDWARE, INCLUDING, BUT NOT LIMITED TO, THE IMPLIED WARRANTIES OF MERCHANTABILITY AND FITNESS FOR A PARTICULAR PURPOSE. To the extent permitted by applicable law, Cypress reserves the right to make changes to this document without further notice. Cypress does not assume any liability arising out of the application or use of any product or circuit described in this document. Any information provided in this document, including any sample design information or programming code, is provided only for reference purposes. It is the responsibility of the user of this document to properly design, program, and test the functionality and safety of any application made of this information and any resulting product. Cypress products are not designed, intended, or authorized for use as critical components in systems designed or intended for the operation of weapons, weapons systems, nuclear installations, life-support devices or systems, other medical devices or systems (including resuscitation equipment and surgical implants), pollution control or hazardous substances management, or other uses where the failure of the device or system could cause personal injury, death, or property damage (“Unintended Uses”). A critical component is any component of a device or system whose failure to perform can be reasonably expected to cause the failure of the device or system, or to affect its safety or effectiveness. Cypress is not liable, in whole or in part, and you shall and hereby do release Cypress from any claim, damage, or other liability arising from or related to all Unintended Uses of Cypress products. You shall indemnify and hold Cypress harmless from and against all claims, costs, damages, and other liabilities, including claims for personal injury or death, arising from or related to any Unintended Uses of Cypress products.

Cypress, the Cypress logo, Spansion, the Spansion logo, and combinations thereof, WICED, PSoC, CapSense, EZ-USB, F-RAM, and Traveo are trademarks or registered trademarks of Cypress in the United States and other countries. For a more complete list of Cypress trademarks, visit [cypress.com](http://cypress.com). Other names and brands may be claimed as property of their respective owners.

ARM and Cortex are the registered trademarks of ARM Limited in the EU and other countries.



## **Purpose of this manual and intended readers**

This manual explains the functions, operations and serial programming of the flash memory of this series. This manual is intended for engineers engaged in the actual development of products using this series.

## **Trademark**

ARM and Cortex are the registered trademarks of ARM Limited in the EU and other countries.

The company names and brand names herein are the trademarks or registered trademarks of their respective owners.

## **Organization of this Manual**

This manual consists of the following 4 chapters.

### **CHAPTER 1 MainFlash Memory**

This chapter gives an overview of, and explains the structure, operation, and registers of the MainFlash memory.

### **CHAPTER 2 WorkFlash Memory**

This chapter gives an overview of, and explains the structure, operation, and registers of the WorkFlash memory.

### **CHAPTER 3 Flash Security**

The flash security feature provides possibilities to protect the content of the flash memory. This chapter section describes the overview and operations of the flash security.

### **CHAPTER 4 Serial Programming Connection**

This chapter explains the basic configuration for serial write to flash memory by using the Cypress Semiconductor Serial Programmer.

## **Sample programs and development environment**

Cypress Semiconductor offers sample programs free of charge for operating the peripheral functions of the FM3 family. Cypress Semiconductor also makes available descriptions of the development environment required for this series. Feel free to use them to verify the operational specifications and usage of this Cypress Semiconductor microcontroller.

## **Microcontroller support information:**

<http://www.cypress.com/cypress-microcontrollers>

## **Note:**

\*: Note that the sample programs are subject to change without notice. Since they are offered as a way to demonstrate standard operations and usage, evaluate them sufficiently before running them on your system. Cypress Semiconductor assumes no responsibility for any damage that may occur as a result of using a sample program.

# How to Use this Guide



## Searching for a function

The following methods can be used to search for the explanation of a desired function in this manual:

- Search from the table of the contents

The table of the contents lists the manual contents in the order of description.

- Search from the register

The address where each register is located is not described in the text. To verify the address of a register, see "APPENDIXES A. Register Map" of "FM3 Peripheral Manual".

## Terminology

This manual uses the following terminology.

Term	Explanation
Word	Indicates access in units of 32 bits.
Half word	Indicates access in units of 16 bits.
Byte	Indicates access in units of 8 bits.

## Notations

- The notations in bit configuration of the register explanation of this manual are written as follows.

bit:	bit number
Field:	bit field name
Attribute:	Attributes for read and write of each bit
R:	Read only
W:	Write only
RW:	Readable/Writable
-:	Undefined
Initial value:	Initial value of the register after reset
0:	Initial value is 0
1:	Initial value is 1
X:	Initial value is undefined

- The multiple bits are written as follows in this manual.  
Example : bit7:0 indicates the bits from bit7 to bit0
  
- The values such as for addresses are written as follows in this manual.  
Hexadecimal number: 0x is attached in the beginning of a value as a prefix  
(example : 0xFFFF)  
Binary number: 0b is attached in the beginning of a value as a prefix (example : 0b1111)  
Decimal number: Written using numbers only (example : 1000)

# Contents



<b>1. MainFlash Memory</b> .....	<b>8</b>
1.1 Overview.....	9
1.2 Configuration .....	10
1.3 Operating Description .....	12
1.3.1 MainFlash Memory Access Modes .....	12
1.3.2 Automatic Algorithm.....	13
1.3.3 Explanation of MainFlash Memory Operation .....	20
1.3.4 Writing to MainFlash Memory in Products Equipped with ECC .....	25
1.3.5 Cautions When Using MainFlash Memory .....	26
1.4 Registers .....	26
1.4.1 FASZR (Flash Access Size Register) .....	27
1.4.2 FRWTR (Flash Read Wait Register).....	28
1.4.3 FSTR (Flash Status Register).....	28
1.4.4 FSYNDN (Flash Sync Down Register).....	30
1.4.5 CRTRMM (CR Trimming Data Mirror Register) .....	31
<b>2. WorkFlash Memory</b> .....	<b>32</b>
2.1 Overview.....	33
2.2 Configuration .....	34
2.3 Operating Description .....	34
2.3.1 WorkFlash Memory Access Modes.....	35
2.3.2 Automatic Algorithm.....	36
2.3.3 Explanation of WorkFlash Memory Operation .....	42
2.3.4 Cautions When Using WorkFlash Memory .....	47
2.4 Registers .....	48
2.4.1 WFASZR (WorkFlash Access Size Register) .....	48
2.4.2 WFRWTR (WorkFlash Read Wait Register) .....	49
2.4.3 WFSTR (WorkFlash Status Register) .....	50
<b>3. Flash Security</b> .....	<b>51</b>
3.1 Overview.....	52
3.2 Operation Explanation .....	53
<b>4. Serial Programming Connection</b> .....	<b>54</b>
4.1 Serial Programmer.....	55
4.1.1 Basic Configuration.....	55

4.1.2 Pins Used .....	60
<b>Revision History.....</b>	<b>61</b>
Document Revision History .....	61

# 1. MainFlash Memory



This series is equipped with 64 KBytes to 128 KBytes of Main Flash memory and 32KBytes of WorkFlash memory.

This chapter gives an overview of, and explains the structure, operation, and registers of the Mai Flash memory. See "CHAPTER WorkFlash Memory" for details of the WorkFlash memory.

This series has built-in MainFlash memory with a capacity of 64 KBytes to 128 KBytes that supports data erasing by all sectors, data erasing by unit of sector and data writing by the CPU.

Contents described with "flash memory" are information for the MainFlash memory in this chapter.

1.1 Overview

1.2 Configuration

1.3 Operating Description

1.4 Registers



## 1.1 Overview

This series is equipped with 64 KBytes to 128 KBytes of built-in MainFlash memory. The built-in MainFlash memory can be erased data sector-by-sector; all-sector batch erased data, and programmed data in units of half-word (16-bit) by the Cortex-M3 CPU. This flash memory also has built-in ECC (Error Correction Code) functionality.

### Flash Memory Features

- Usable capacity:
  - Minimum configuration: 64 Kbytes
  - Maximum configuration: 128 Kbytes

Because this series stores ECC codes, it is equipped with additional flash memory of 7 bits for every 4 bytes of memory described above.
- High-speed flash:
  - Up to 40MHz: 0Wait
- Operating mode:
  1. CPU ROM mode
    - This mode only allows reading of flash memory data. Word access is available. However, in this mode, it is not possible to activate the automatic algorithm\*1 to perform writing or erasing.
  2. CPU programming mode
    - This mode allows reading, writing, and erasing of flash memory (automatic algorithm\*1). Because word access is not available, programs that are contained in the flash memory cannot be executed while operating in this mode. Half-word access is available.
  3. ROM writer mode
    - This mode allows reading, writing, and erasing of flash memory from a ROM writer (automatic algorithm\*1).
- Built-in flash security function (Prevents reading of the content of flash memory by a third party)
  - See "CHAPTER Flash Security" for details on the flash security function.
- Equipped with an Error Correction Code (ECC) function that can correct up to 1 bit of errors in each word.(The device is not equipped with a function to detect 2-bit errors.) Errors are automatically corrected when memory is read.
  - Furthermore, ECC codes are automatically added upon writing to flash memory. Because there are no read cycle penalties as a result of error correction, it is not necessary to consider the error correction penalties during software development.

### Note:

- This document explains flash memory in the case where it is being used in CPU mode.
- For details on accessing the flash memory from a ROM writer, see the instruction manual of the ROM writer that is being used.

\*1: Automatic algorithm=Embedded Algorithm

## 1.2 Configuration

This series consists of 64 KBytes to 128 KBytes MainFlash memory area, a security code area, and a High-Speed CR trimming data area.

Figure 1-1 to Figure 1-3 shows the address and sector structure of the MainFlash memory built into this series as well as the address of security/CR trimming data.

See "CHAPTER Flash Security" for details on the security.

See Section "1.4.5 CRTRMM (CR Trimming Data Mirror Register) " and "CHAPTER High-Speed CR Trimming" of the "FM3 Peripheral Manual" for details on the High-Speed CR trimming data.

Figure 1-1. Memory map of M9AF111K/311K MainFlash memory

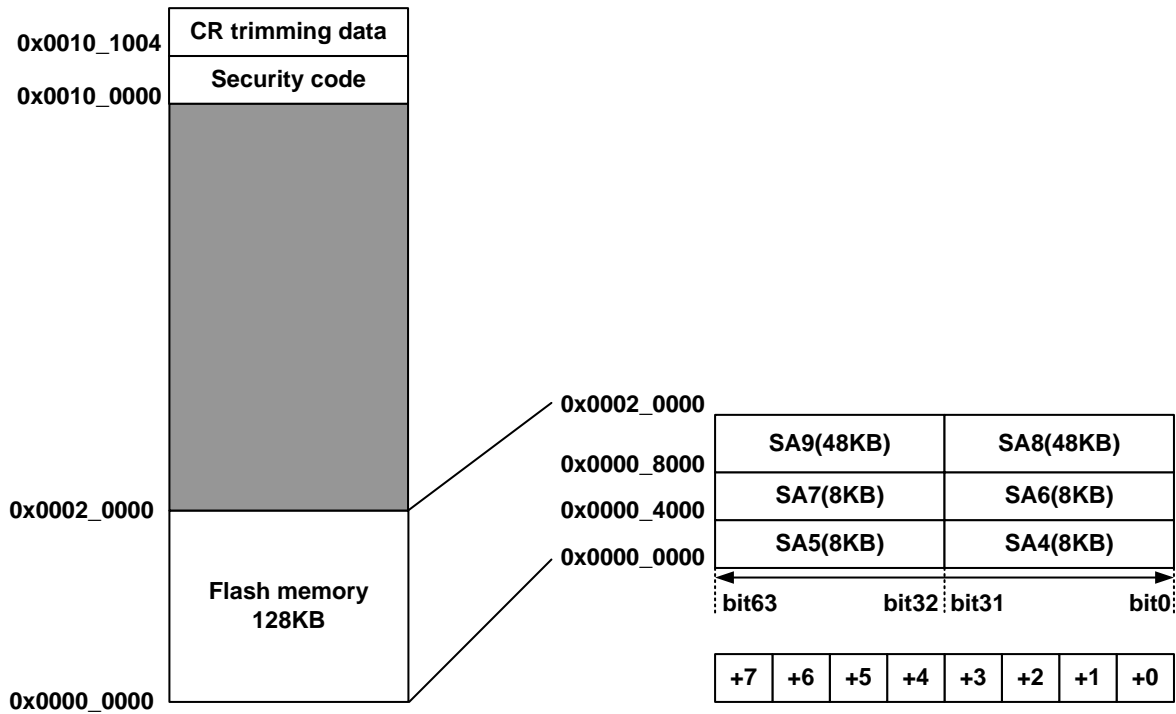

Figure 1-2. Memory map of M9AF112K/312K MainFlash memory

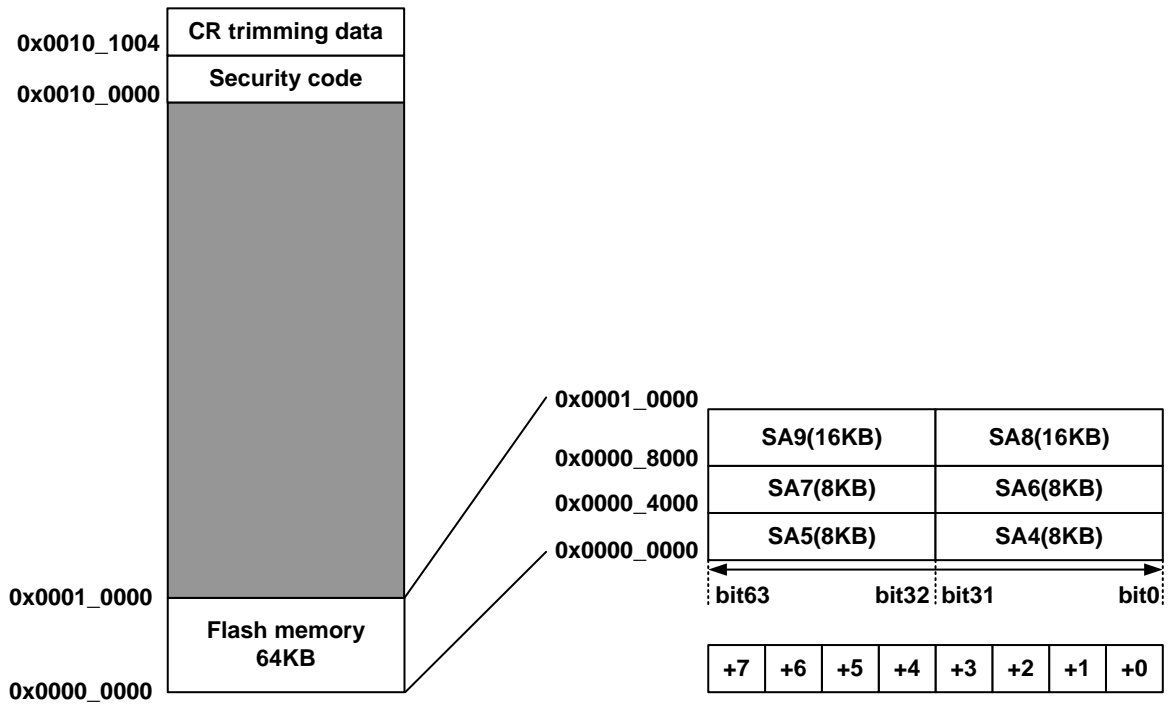
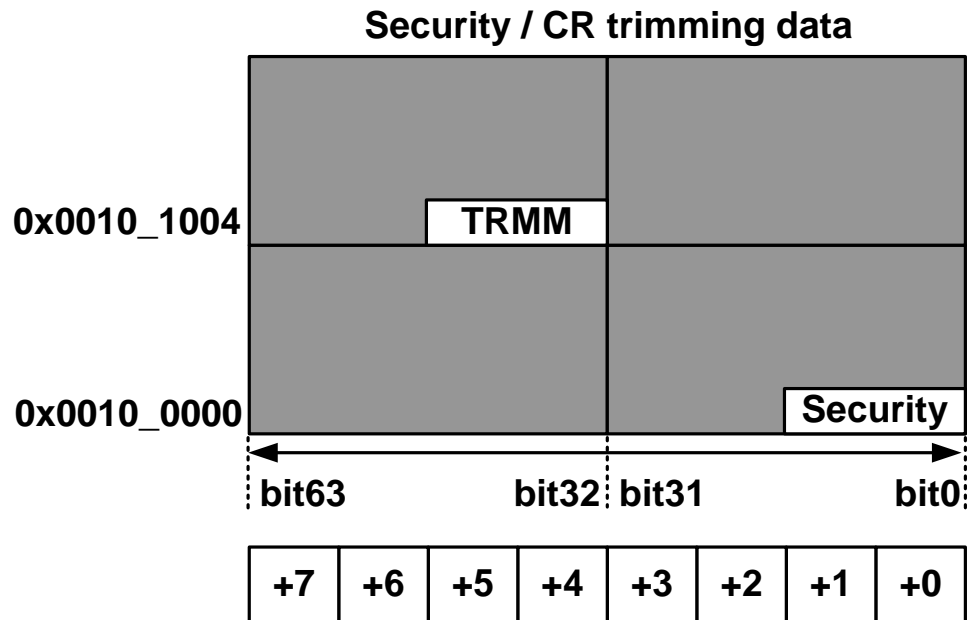

Figure 1-3. Address of Security/CR trimming data



## 1.3 Operating Description

This section explains the MainFlash memory operation.

### 1.3.1 MainFlash Memory Access Modes

#### 1.3.2 Automatic Algorithm

#### 1.3.3 Explanation of MainFlash Memory Operation

#### 1.3.4 Writing to MainFlash Memory in Products Equipped with ECC

#### 1.3.5 Cautions When Using MainFlash Memory

### 1.3.1 MainFlash Memory Access Modes

The following two access modes are available for accessing MainFlash memory from the CPU.

- CPU ROM mode
- CPU programming mode

These modes can be selected by the flash access size bits (FASZR: ASZ).

#### **CPU ROM Mode**

This mode only allows reading of flash memory data.

This mode is entered by setting the flash access size bits (FASZR: ASZ) to "10" (32-bit read), and enables word access.

However, in this mode, it is not possible to execute commands, to activate the automatic algorithm or to write or erase data.

The flash memory always enters this mode after reset is released.

#### **CPU Programming Mode**

This mode allows reading, writing, and erasing of data.

This mode is entered by setting the flash access size bits (FASZR: ASZ) to "01" (16-bit read/write), and enables flash programming.

Because word access is not possible in this mode, programs that are contained in the flash memory cannot be executed. The operation while in this mode is as follows.

- During reading

Flash memory is accessed in half-word, with data read out in blocks of 16 bits.

- During writing commands

The automatic algorithm can be activated to write or erase data. See Section "1.3.2 Automatic Algorithm" for details on the automatic algorithm.

Table 1-1. Access Modes of Flash memory

Access Mode	Access Size	Automatic Algorithm	Instruction execution in the Flash Memory
CPU ROM mode	32bit	disable	enable
CPU programming mode	16bit	enable	Prohibited

**Note:**

- The flash memory is always set to CPU ROM mode when a reset is released. Therefore, if a reset occurs after entering CPU programming mode, the flash access size bits (FASZR: ASZ) are set to "10" and the flash memory returns to CPU ROM mode.

### 1.3.2 Automatic Algorithm

When CPU programming mode is used, writing to and erasing MainFlash memory is performed by activating the automatic algorithm.

This section explains the automatic algorithm.

#### 1.3.2.1 Command Sequences

#### 1.3.2.2 Command Operating Explanations

#### 1.3.2.3 Automatic Algorithm Run States

#### 1.3.2.1 Command Sequences

The automatic algorithm is activated by sequentially writing half-word (16-bit) data to the MainFlash memory one to six times in a row. This is called a command. Table 1-2 shows the command sequences.

Table 1-2. Command Sequence Chart

Command	Number of writes	1st write		2nd write		3rd write		4th write		5th write		6th write	
		Address	Data	Address	Data	Address	Data	Address	Data	Address	Data	Address	Data
Read/Reset	1	0xXXX	0xF0	--	--	--	--	--	--	--	--	--	--
Write	4	0x1550	0xAA	0xAA8	0x55	0x1550	0xA0	PA	PD	--	--	--	--
Flash erase	6	0x1550	0xAA	0xAA8	0x55	0x1550	0x80	0x1550	0xAA	0xAA8	0x55	0x1550	0x10
Sector erase	6	0x1550	0xAA	0x AA8	0x55	0x1550	0x80	0x1550	0xAA	0xAA8	0x55	SA	0x30
Sector erase suspended	1	0xXXX	0xB0	--	--	--	--	--	--	--	--	--	--
Sector erase restarting	1	0xXXX	0x30	--	--	--	--	--	--	--	--	--	--

X: Any value

PA: Write address

SA: Sector address (Specify any address within the address range of the sector to erase)

PD: Write data

**Notes:**

- The data notation in Table 1-2 only shows the lower 8 bits. The upper 8 bits can be set to any value.
- Write commands as half-word at any time.
- The address notation in Table 1-2 only shows the lower 16 bits. The upper 16 bits should be set to any address within the address range of the target flash memory. When the address outside the flash address range is specified, the command sequence would not move correctly since the flash memory cannot recognize the command.
- "Address within the address range" specified when setting or erasing the security code should be 0x0010\_0000.
- "Address within the address range" specified when setting or erasing the CR trimming data should be 0x0010\_1004.

### 1.3.2.2 *Command Operating Explanations*

This section explains the command operating.

**Read/Reset Command**

The flash memory can be read and reset by sending the read/reset command to the target sector in sequence.

When a read/reset command is issued, the flash memory maintains the read state until another command is issued.

When the execution of the automatic algorithm exceeds the time limit, the flash memory is returned to the read/reset state by issuing the read/reset command.

See Section "1.3.3.1 Read/Reset Operation" for details on the actual operation.

**Program (Write) Command**

The automatic algorithm can be activated and the data is written to the flash memory by issuing the write command to the target sector in four consecutive writes. Data writes can be performed in any order of addresses, and may also cross sector boundaries.

In CPU programming mode, data is written in half-word.

Once the forth command issuance has finished, the automatic algorithm is activated and the automatic write to the flash memory starts. After executing the automatic write algorithm command sequence, there is no need to control the flash memory externally.

See Section "1.3.3.2 Write Operation" for details on the actual operation.

**Notes:**

- The command is not recognized properly if the fourth write command (write data cycle) is issued to an odd address. Always issue it to an even address.
- Only a single half-word of data can be written for each write command sequence.  
To write multiple pieces of data, issue one write command sequence for each piece of data.

**Flash Erase Command**

All of the sectors in flash memory can be batch-erased by sending the flash erase command to the target sector in six consecutive writes. Once the sixth sequential write has finished, the automatic algorithm is activated and the flash erase operation starts.

**Sector Erase Command**

A single sector of flash memory can be erased by sending the sector erase command to the target sector in six consecutive writes. Once the sixth sequential write has finished and 35  $\mu$ s has elapsed (timeout interval), the automatic algorithm is activated and the sector erase operation begins.

To erase multiple sectors, issue the sector erase code (0x30) which is the sixth write code of the sector erase command to the address of the sector to erase within 35  $\mu$ s (timeout interval). If the sector erase code is not issued within the timeout interval, the sector erase code added after the timeout interval has elapsed may become inactive.

**Sector Erase Suspended Command**

By issuing the sector erase suspended command during sector erase or during command timeout, sector erase can be suspended. In the sector erase suspended state, the read operation of memory cells of the sector not to erase is made possible.

See Section "1.3.3.5 Sector Erase Suspended Operation" for details on the actual operation.

**Note:**

This command is only valid during sector erase. It is ignored even if it is issued during flash erase or during write.

**Sector Erase Restart Command**

In order to restart the erase operation in the sector erase suspended state, issue the sector erase restart command. Issuing the sector erase restart command returns the flash memory to the sector erase state and restarts the erase operation.

See Section "1.3.3.6 Sector Erase Restart Operation" for details on the actual operation.

**Note:**

This command is only valid during sector erase suspended. It is ignored even if it is issued during sector erase.

**1.3.2.3 Automatic Algorithm Run States**

Because writing and erasing of flash memory is performed by the automatic algorithm, whether or not the automatic algorithm is currently executing can be checked using the flash ready bit (FSTR: RDY) and the operating status can be checked using the hardware sequence flags.

**Hardware Sequence Flags**

These flags indicate the status of the automatic algorithm. When the flash ready bit (FSTR: RDY) is "0", the operating status can be checked by reading any address in flash memory.

Figure 1-4 shows the bit structure of the hardware sequence flags.

Figure 1-4. Bit structure of the hardware sequence flags

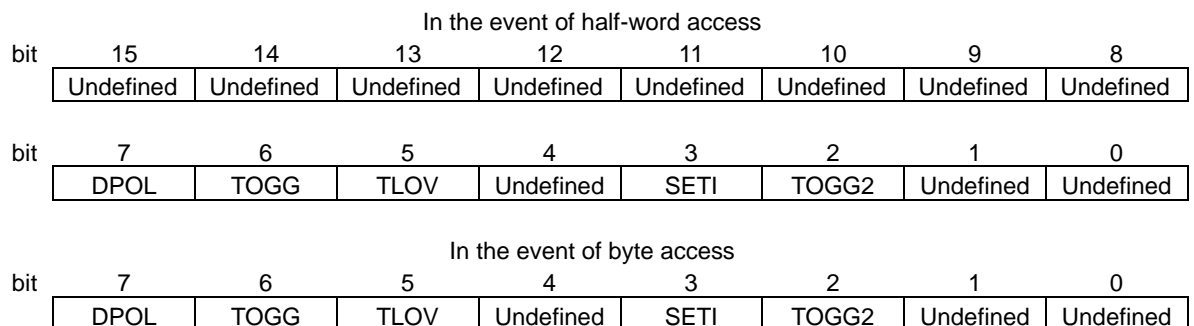

**Notes:**

- These flags cannot be read using word access. When in CPU programming mode, always read using half-word or byte access.
- In CPU ROM mode, the hardware sequence flags cannot be read no matter which address is read.
- Because the correct value might not be read out immediately after issuing a command, ignore the first value of the hardware sequence flags that is read after issuing a command.

**Status of each bit and MainFlash memory**

Table 1-3 shows the correspondence between each bit of the hardware sequence flags and the status of the flash memory.

Table 1-3. List of hardware sequence flag states

State		DPOL	TOGG	TLOV	SETI	TOGG2		
Running	Automatic write operation	Inverted data (*1)	Toggle	0	0	0		
	Automatic Erase operation	Flash erase	0	Toggle	0	1	Toggle	
		Sector erase	timeout interval	0	Toggle	0	0	Toggle
			erase	0	Toggle	0	1	Toggle
		Sector erase suspended	Read (Sector to erase)	0	0	0	1	Toggle
Read (Sector not to erase)	Data (*1)		Data (*1)	Data (*1)	Data (*1)	Data (*1)		
Time limit exceeded	Write operation	Inverted data (*1)	Toggle	1	0	0		
	Sector/Flash erase	0	Toggle	1	1	Toggle		

\*1 See "Bit Descriptions" for the values that can be read.



**Bit Descriptions**

[bit15:8] Undefined bits

**[bit7] DPOL: Data polling flag bit**

When the hardware sequence flags are read, by specifying an arbitrary address, this bit uses a data polling function to indicate whether or not the automatic algorithm is currently running.

The value that is read out varies depending on the operating state.

- During writing
  - While write is in progress:  
Reads out the opposite value (inverse data) of bit 7 of data written at the last command sequence (PD). This does not access the address that was specified for reading the hardware sequence flags.
  - After write finishes:  
Reads out the value of bit 7 of the address specified for reading the hardware sequence flags.
- During sector erase
  - While sector erase is executing:  
Reads out "0" from all areas of flash memory.
  - After sector erase finishes:  
Always reads out "1".
- During flash erase
  - While flash erase is executing: Always reads out "0".
  - After flash erase: Always reads out "1".
- During sector erase suspended
  - When this bit is read out by specifying an address in the sector specified as sector erase:  
Reads out "0".
  - When this bit is read out by specifying an address in the sector other than specified as sector erase:  
Reads out the value of bit 7 of a specified address.

**Note:**

The data for a specified address cannot be read while the automatic algorithm is running. Confirm that the automatic algorithm has finished running by using this bit before reading data.

**[bit6] TOGG: Toggle Flag Bit**

When the hardware sequence flags are read by specifying an arbitrary address, this bit indicates whether or not the automatic algorithm is currently running.

The value that is read out varies depending on the operating state.

- During write, sector erase, or flash erase
  - While write, sector erase, or flash erase is in progress:  
When this bit is read out continuously, it alternating returns "1" and "0" (toggles). The address that was specified for reading the hardware sequence flags is not accessed.
  - After write, sector erase, or flash erase has finished:  
Reads out the value of bit 6 of the address specified for reading the hardware sequence flags.
- During sector erase suspended
  - When this bit is read out by specifying an address in the sector specified as sector erase:  
Reads out "0".
  - When this bit is read out by specifying an address in the sector other than specified as sector erase:  
Reads out the value of bit 6 of a specified address.

**[bit5] TLOV: Timing Limit Exceeded Flag Bit**

When the hardware sequence flags are read by specifying an arbitrary address, this bit indicates whether or not the execution time of the automatic algorithm has exceeded the rated time defined internally within the flash memory (number of internal pulses).

The value that is read out varies depending on the operating state.

- During write, sector erase, or flash erase
  - The following values are read out.  
0: Within the rated time  
1: Rated time exceeded
  - When this bit is "1", if the DPOL bit and TOGG bit indicate that the automatic algorithm is currently executing, that means a failure occurred during the write or erase.  
  
For example, because data that has been written to "0" cannot be overwritten to "1" in flash memory, if "1" is written to an address that has been written to "0", the flash memory is locked and the automatic algorithm does not finish. In this case, the value of the DPOL bit remains invalid, and "1" and "0" are continuously read out alternating from the TOGG bit.  
  
Once the rated time is exceeded while still in this state, this bit changes to "1". If this bit changes to "1", issue the reset command.
- During sector erase suspended
  - When this bit is read out by specifying an address in the sector specified as sector erase:  
Reads out "0".
  - When this bit is read out by specifying an address in the sector other than specified as sector erase:  
Reads out the value of bit 5 of a specified address.

**Note:**

If this bit is "1", it indicates that the flash memory was not used correctly. This is not a malfunction of the flash memory.

Perform the appropriate processing after issuing the reset command.

**[bit4] Undefined bit****[bit3] SETI: Sector Erase Timer Flag Bit**

When a sector is erased, a timeout interval of 35  $\mu$ s is required from when the sector erase command is issued until the sector erase actually begins.

When the hardware sequence flags are read by specifying an arbitrary address, this bit indicates whether or not the flash memory is currently in the sector erase command timeout interval.

The value that is read out varies depending on the operating state.

**■ During sector erase:**

When sectors are being erasing, it can be checked whether or not the following sector erase code can be accepted by checking this bit before inputting the following sector erase code.

The following values are read out without accessing the address specified in order to read the hardware sequence flags.

0: Within sector erase timeout interval

The following sector erase code (0x30) can be accepted.

1: Sector erase timeout interval exceeded

In this case, if the DPOL bit and TOGG bit indicate that the automatic algorithm is currently executing, the erase operation has started internally within the flash memory. In this case, commands other than the sector erase suspended (0xB0) are ignored until the internal flash memory erase operation has finished.

**■ During sector erase suspended**

- When this bit is read out by specifying an address in the sector specified as sector erase:

Reads out "1".

- When this bit is read out by specifying an address in the sector other than specified as sector erase:

Reads out the value of bit 3 of a specified address.

**[bit2] TOGG2 : Toggle flag bit**

In the sector erase suspended state, a sector which is not the erase target can be read. However, the erase target sector cannot be read. This toggle bit flag can detect whether the corresponding sector is the erase target sector during the sector erase suspend by checking the toggle operation of the read data.

**■ During writing**

Reads out "0".

**■ During sector erase or flash erase**

When this bit is read out continuously, "1" and "0" are alternately read (toggle operation).

**■ During sector erase suspended**

- When this bit is read out by specifying an address in the sector specified as sector erase:

When this bit is read out continuously, "1" and "0" are alternately read (toggle operation)

- When this bit is read out by specifying an address in the sector other than specified as sector erase:

Reads out the value of bit 2 of a specified address.

**[bit1:0] Undefined bits**

### 1.3.3 Explanation of MainFlash Memory Operation

The operation of the MainFlash memory is explained for each command.

#### 1.3.3.1 Read/Reset Operation

#### 1.3.3.2 Write Operation

#### 1.3.3.3 Flash Erase Operation

#### 1.3.3.4 Sector Erase Operation

#### 1.3.3.5 Sector Erase Suspended Operation

#### 1.3.3.6 Sector Erase Restart Operation

#### 1.3.3.1 *Read/Reset Operation*

This section explains the read/reset operation.

To place the flash memory in the read/reset state, send read/reset commands to the target sector consecutively..

Because the read/reset state is the default state of the flash memory, the flash memory always returns to this state when the power is turned on or when a command finishes successfully. When the power is turned on, there is no need to issue a data read command. Furthermore, because data can be read by normal read access and programs can be accessed by the CPU while in the read/reset state, there is no need to issue read/reset commands.

#### 1.3.3.2 *Write Operation*

This section explains the write operation.

Writes are performed according to the following procedure.

1. The write command is issued to the target sector sequentially

The automatic algorithm activates and the data is written to the flash memory.

After the write command is issued, there is no need to control the flash memory externally.

2. Perform read access on the address that was written

The data that is read is the hardware sequence flags. Therefore, once bit 7 (the DPOL bit) of the read data matches the value that was written, the write to the flash memory has finished. If the write has not finished, the reverse value (inverted data) of bit 7 written at the last command sequence (PD) is read out.

Figure 1-5 shows an example of a write operation to the flash memory.

Figure 1-5. Example write operation

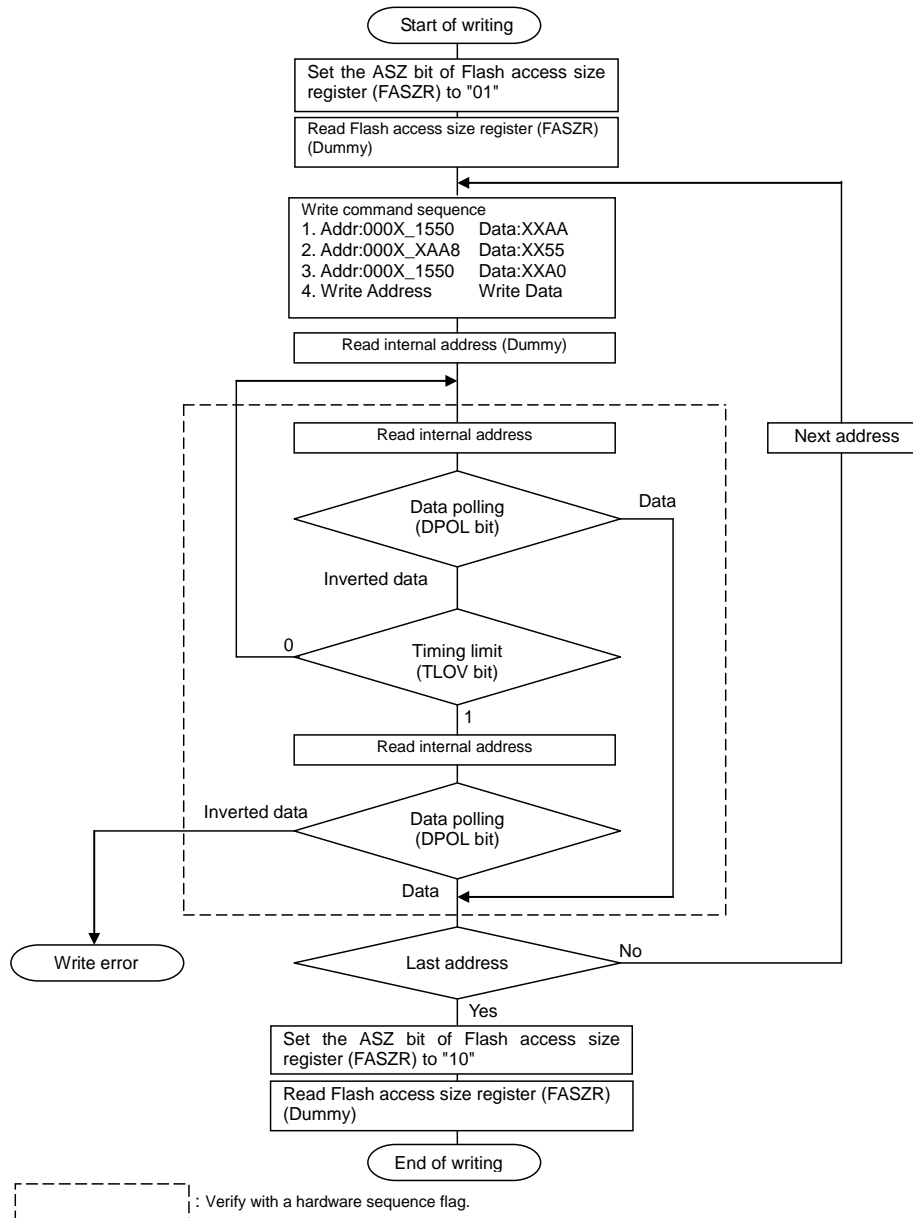

**Notes:**

- See Section "1.3.2 Automatic Algorithm" for details on the write command.
- Because the value of the DPOL bit of the hardware sequence flags changes at the same time as the TLOV bit, the value needs to be checked again even if the TLOV bit is "1".
- The toggle operation stops at the same time as the TOGG bit and TLOV bit of the hardware sequence flags change to "1". Therefore, even if the TLOV bit is "1", the TOGG bit needs to be checked again.
- Although the flash memory can be written in any sequence of addresses regardless of crossing sector boundaries, only a single half-word of data can be written with each write command sequence. To write multiple pieces of data, issue one write command sequence for each piece of data.

- All commands issued to the flash memory during the write operation are ignored.
- If the device is reset while the write is in progress, the data that is written is not guaranteed.

### 1.3.3.3 *Flash Erase Operation*

This section explains the flash erase operation.

All sectors in flash memory can be erased in one batch. Erasing all of the sectors in one batch is called flash erase.

The automatic algorithm can be activated and all of the sectors can be erased in one batch by sending the flash erase command sequentially to the target sector.

See Section "1.3.2 Automatic Algorithm" for details on the flash erase command.

1. Issue the flash erase command sequentially to the target sector

The automatic algorithm is activated and the flash erase operation of the flash memory begins.

2. Perform read access to an arbitrary address

The data that is read is the hardware sequence flag. Therefore, if the value of bit 7 (the DPOL bit) of the data that was read is "1", that means the flash erase has finished.

The time required to erase the flash is "sector erase time x total number of sectors + flash write time (preprogramming)".

Once the flash erase operation has finished, the flash memory returns to read/reset mode.

### 1.3.3.4 *Sector Erase Operation*

This section explains the sector erase operation.

Sectors in the flash memory can be selected and the data of only the selected sectors can be erased. Multiple sectors can be specified at the same time.

Sectors are erased according to the following sequence.

1. Issue the sector erase command sequentially to the target sector

Once 35  $\mu$ s has elapsed (the timeout interval), the automatic algorithm activates and the sector erase operation begins.

To erase multiple sectors, issue the erase code (0x30) to an address in the sector to erase within 35  $\mu$ s (the timeout interval). If the code is issued after the timeout interval has elapsed, the added sector erase code may be invalid.

2. Perform read access to an arbitrary address

The data that is read is the hardware sequence flags. Therefore, if the value of bit 7 (the DPOL bit) of the data that was read is "1", that means the sector erase has finished.

Furthermore, it can be checked whether or not the sector erase has finished by using the TOGG bit. Figure 1-6 shows an example of the sector erase procedure for the case of using the TOGG bit for confirmation.

Figure 1-6. Example Sector Erase Procedure

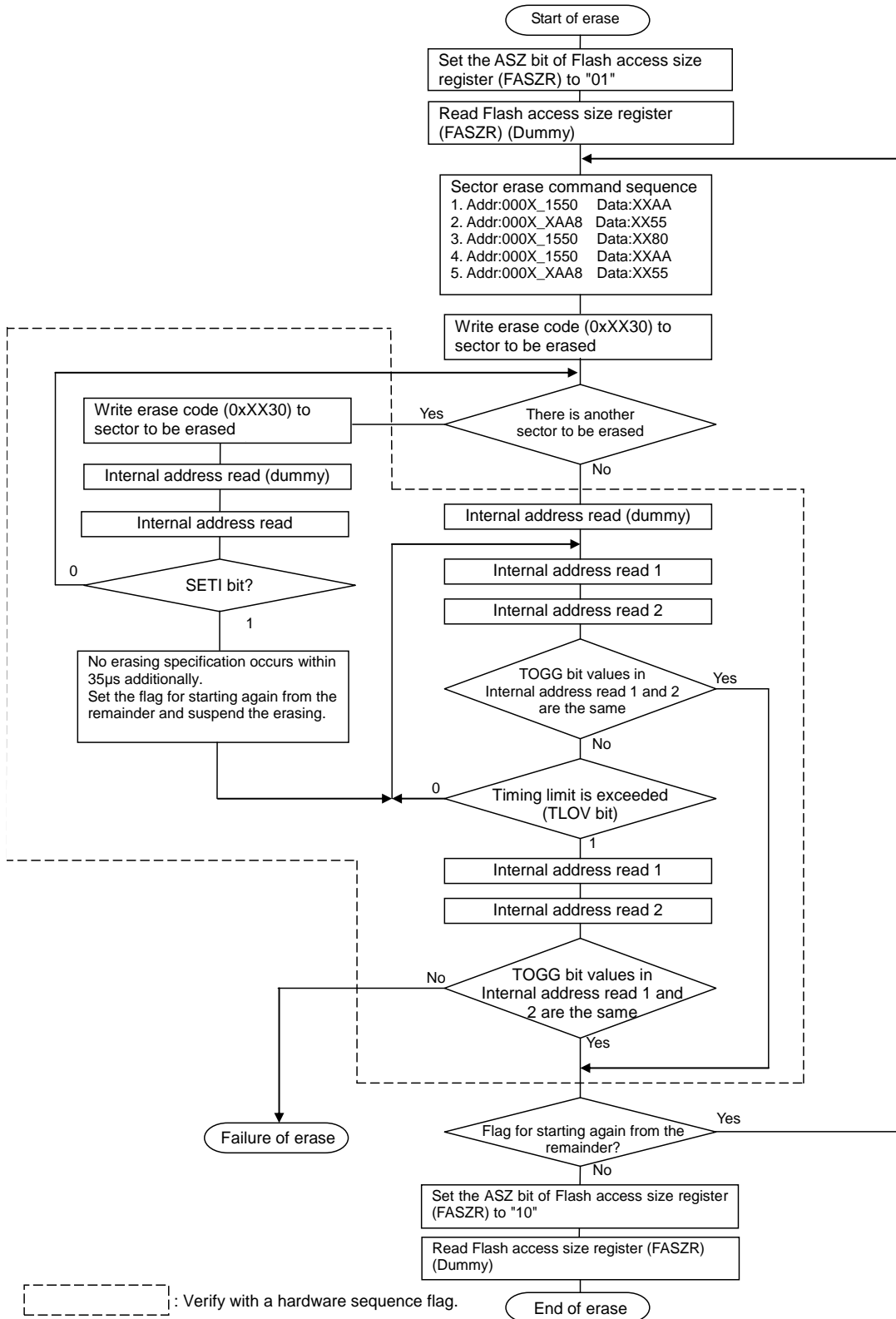

The time required to erase a sector is "(sector erase time + sector write time (preprogramming)) × number of sectors".

Once the sector erase operation has finished, the flash memory returns to read/reset mode.

**Notes:**

- See Section "1.3.2 Automatic Algorithm" for details on the sector erase command.
- Because the value of the DPOL bit of the hardware sequence flags changes at the same time as the TLOV bit, the value needs to be checked again even if the TLOV bit is "1".
- The toggle operation stops at the same time as the TOGG bit and TLOV bit of the hardware sequence flags change to "1". Therefore, even if the TLOV bit is "1", the TOGG bit needs to be checked again.
- If a command other than the sector erase command or the erase suspended command is issued during sector erase, including the timeout interval, it is ignored.

### 1.3.3.5 Sector Erase Suspended Operation

This section explains the sector erase suspended operation.

When the sector erase suspended command is sent during sector erase or in the command timeout state, the flash memory makes a transition to the sector erase suspended state and temporarily suspends the erase operation.

By sending the erase restart command, the flash memory is returned to the sector erase state and can restart the suspended erase operation. However, even if the flash memory has changed from the command timeout state to the sector erase suspended state, when the erase restart command is written properly, the flash memory does not make a transition to the command timeout state but make a transition to the sector erase state and restarts the sector erase operation immediately.

#### Sector Erase Suspended Operation

Sector erase is suspended in the following steps:

1. Write the sector erase suspended command to an arbitrary address within the address range of the flash memory during the time between the command timeout interval and the sector erase interval.
2. If the sector erase suspended command is issued during the command timeout interval, stop timeout immediately and suspend the erase operation. If the sector erase suspended command is issued during sector erase, it takes up to 35  $\mu$ s until erasing is actually stopped.

**Notes:**

- See Section "1.3.2 Automatic Algorithm" for details on the sector erase suspended command.
- Sector erase can only be suspended during the time between the command timeout interval and the sector erase interval. Flash erase cannot be suspended. In addition, even if the sector erase suspended command is issued again during sector erase suspended, it is ignored.

#### State after Sector Erase Suspended

If a sector to erase is read out after sector erase suspended, the hardware sequence flag is read out. On the other hand, if a sector not to erase is read out, data of a memory cell is read out.

**Note:**

New write and erase commands are ignored in the sector erase suspended state.



### 1.3.3.6 Sector Erase Restart Operation

This section explains the operation for restarting sector erase during sector erase suspended.

When the sector erase restart command is issued to an arbitrary address while sector erase is suspended, sector erase can be restarted.

When the sector erase restart command is issued, the sector erase operation during sector erase suspended is restarted.

See Section "1.3.2 Automatic Algorithm" for details on the sector erase restart command.

#### Notes:

- The sector erase restart command is only valid during sector erase suspended. Even if the sector erase restart command is issued during sector erase, it is ignored.
- After the sector erase restart command is issued, it takes more than 2ms until the sector erase operation is restarted. Therefore, when erase restart and erase stop are repeated at intervals less than this time, timing limit is exceeded while no erase operation is in progress. If the sector erase suspended command is to be issued again after the sector erase restart command is issued, leave an interval more than 2ms after the sector erase restart command is issued.

### 1.3.4 Writing to MainFlash Memory in Products Equipped with ECC

This section explains the writing to MainFlash memory in products equipped with ECC.

Because ECC (Error Correction Codes) are attached to each word in this series, writes need to be performed in blocks of words. Write the data one word at a time by writing two half-word consecutively using the following procedure. If this procedure is not followed, the data is written to the flash memory without calculating the ECC, and the written data will not be read correctly.

1. Set the flash access size setting to 16 bits. (FASZR: ASZ="01")  
Perform a dummy read, after setting the FASZR register.
2. Issue a write command. Write address = PA Write data = PD[15:0]  
See Section "1.3.3.2 Write Operation" for details on the write command.
3. Read the hardware sequence flags once. Because the correct value might not be read out immediately after issuing a command, this read value should be ignored.
4. Read the hardware sequence flags until the write has finished.  
See Section "1.3.2.3 Automatic Algorithm Run States" for details on reading the hardware sequence flags.
5. Issue a write command. Write address = PA+2 Write data = PD[31:16]  
At this time, the hardware automatically calculates the ECC codes together with PD[15:0] from step 2, and also automatically writes the ECC codes at the same time.
6. Read the hardware sequence flags once. Because the correct value might not be read out immediately after issuing a command, this read value should be ignored.
7. Read the hardware sequence flags until the write has finished.
8. If there is more write data, return to step 2. Once finished writing all of the data, proceed to step 9.
9. Switch to CPU ROM mode. Set the flash access size setting to 32 bits.  
(FASZR: ASZ="10")  
Perform a dummy read, after setting the FASZR register.
10. Read the value that was written, and check that the correct value can be read. Furthermore, even if the correct value was read, check the flash error bits (FSTR: ERR) to ensure that there have been no ECC corrections. If an ECC correction has occurred, erase the flash memory and start again from the beginning.

PA: Write address (word-aligned)  
 PD[31:0]: Write data  
 PD[31:16]: Upper 16 bits of the write data  
 PD[15:0]: Lower 16 bits of the write data

### 1.3.5 Cautions When Using MainFlash Memory

This section explains the cautions when using MainFlash memory.

- If this device is reset during the write, the data that is written cannot be guaranteed. Moreover, It is necessary to prevent an unexpected reset like Watchdog Timer from occurring during the writing and deleting.
- If the CPU programming mode is configured (ASZ=01) in the ASZ[1:0] bits of the flash access size register (FASZR), do not execute any programs in the flash memory. The correct values will not be retrieved and the program will run out of control.
- If the CPU programming mode is configured (ASZ=01) in the ASZ[1:0] bits of the flash access size register (FASZR) and the interrupt vector table is in the flash memory, ensure that no interrupt requests occur. The correct values will not be retrieved and the program will run out of control.
- If the CPU programming mode is configured (ASZ=01) in the ASZ[1:0] bits of the flash access size register (FASZR), do not transition to low power consumption mode.
- If the CPU ROM mode is configured (ASZ=10) in the ASZ[1:0] bits of the flash access size register (FASZR), do not write to the flash memory.
- If the CPU programming mode is configured (ASZ=01) in the ASZ[1:0] bits of the flash access size register (FASZR), always write to the flash memory in half-word. Do not write in bytes.
- Immediately after issuing the automatic algorithm command to the flash memory, always perform a dummy read before reading the data that is actually wanted. If data is read immediately after issuing the automatic algorithm command, the read value cannot be guaranteed.
- If the device is forced to transit to the low power consumption mode, ensure the operations of the flash memory automatic algorithm is completed.  
 See "CHAPTER Low Power Consumption Mode" of the "FM3 Peripheral Manual" for details on the low power consumption mode.

## 1.4 Registers

This section explains the registers.

Table 1-4. List of Registers

Abbreviated Register Name	Register Name	Reference
FASZR	Flash Access Size Register	1.4.1
FRWTR	Flash Read Wait Register	1.4.2
FSTR	Flash Status Register	1.4.3
FSYNDN	Flash Sync Down Register	1.4.4
CRTRMM	CR Trimming Data Mirror Register	1.4.5

### 1.4.1 FASZR (Flash Access Size Register)

This section explains the FASZR.

This register configures the access size for flash memory. After reset is released, ASZ is set to "10" (32-bit read), and the flash memory enters CPU ROM mode. To put the flash memory into CPU programming mode, set ASZ to "01".

bit	7	6	5	4	3	2	1	0
Field	Reserved						ASZ	
Attribute							RW	RW
Initial value							1	0

Field	bit	Description
ASZ	1:0	Flash Access Size Specifies the access size of the flash memory. 00 : Setting prohibited 01 : 16-bit read/write (CPU programming mode) 10 : 32-bit read (CPU ROM mode: Initial value) 11 : Setting prohibited

**Notes:**

- When ASZ is set to "01", always perform writes to flash using half-word access (16-bit access).
- Do not change this register using an instruction that is contained in the flash memory. Overwrite this register from a program in any other area except for flash memory.
- Perform a dummy read to register, after changing this register.

### 1.4.2 FRWTR (Flash Read Wait Register)

This section explains the FRWTR.

This register is effective when ASZ="10" (32-bit read mode).  
It configures the access method for flash memory.

bit	7	6	5	4	3	2	1	0
Field	Reserved						RWT	
Attribute							RW	R
Initial value							0	0

Field	bit	Description
RWT	1:0	Read Wait Cycle Specifies the access method for flash memory. 00 : 0 cycle wait mode (0 latency) 01 : Setting prohibited 10 : Setting prohibited 11 : Setting prohibited

**Note:**

Do not set RWT to "00"(0 cycle wait mode).

### 1.4.3 FSTR (Flash Status Register)

This section explains the FSTR.

This is a status register of flash memory.

bit	7	6	5	4	3	2	1	0
Field	Reserved					ERR	HNG	RDY
Attribute						RW	R	R
Initial value						0	0	X

**[bit7:3] Reserved bits**

The read values are undefined. Ignored on write.

**[bit2] ERR: Flash ECC Error**

This bit is set to "1" if ECC error correction occurs.

Field	bit	Description
ERR	2	Flash ECC Error On read: 0 : Correction due to an ECC error has not occurred. 1 : Correction due to an ECC error has occurred. On write: 0 : Clears this bit. 1 : Ignored.

**[bit1] HNG: Flash Hang**

Indicates whether the flash memory is in the HANG state. Flash memory enters the HANG state if the timing is exceeded (See "[bit5] TLOV: Timing Limit Exceeded Flag Bit"). If this bit becomes "1", issue a reset command (See Section "1.3.2.1 Command Sequences").

Because the correct value might not be read out immediately after issuing an automatic algorithm command, ignore the value of this bit as read out the first time after a command is issued.

Field	bit	Description
HNG	1	Flash Hang 0 : The flash memory HANG state has not been detected. 1 : The flash memory HANG state has been detected.

**[bit0] RDY: Flash Rdy**

Indicates whether a flash memory write or erase operation using the automatic algorithm is in progress or finished. While an operation is in progress, data cannot be written and the flash memory cannot be erased.

Field	bit	Description
RDY	0	Flash Rdy 0 : Operation in progress (cannot write or erase) 1 : Operation finished (can write or erase)

Because the correct value might not be read immediately after an automatic algorithm command is issued, ignore the value of this bit as read the first time after a command is issued.

### 1.4.4 FSYN DN (Flash Sync Down Register)

This section explains the FSYN DN.

The wait cycle is inserted in the read access to the flash memory at the CPU ROM mode. Current consumption can be reduced by decreasing the access clock frequency of the flash memory.

bit	7	6	5	4	3	2	1	0
Field	Reserved					SD		
Attribute						RW	RW	RW
Initial value						0	0	0

Field	bit	Description
SD	2:0	000 : 0 (Initial value) 001 : +1 wait 010 : Setting prohibited 011 : +3 wait 100 : Setting prohibited 101 : +5 wait 110 : Setting prohibited 111 : +7 wait

The number of wait set by this bit is added to the RWT bits of the flash read wait register (FRWTR).

Example)

in case of RWT=00 (0cycle wait) and SD=011, 0+3=3 wait

**Note:**

Perform a dummy read to register, after changing this register.

### 1.4.5 CRTRMM (CR Trimming Data Mirror Register)

This section explains the CRTRMM.

This is the mirror register of the CR trimming data.

A value of this register can be used in the user mode and the serial writer mode.

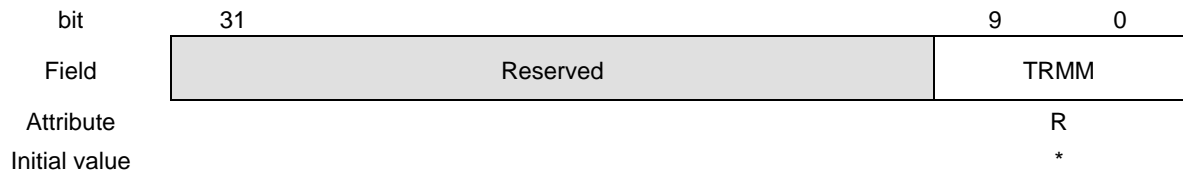

#### [bit9:0] TRMM : CR Trimming Data Mirror Register

After reset is released, store the data in an address of 0x0010\_1004 of the flash memory area into this register. See "CHAPTER High-Speed CR Trimming" of the "FM3 Peripheral Manual" for details on the High-Speed CR trimming data.

Field	bit	Description
TRMM	9:0	*: Reads out lower 10 bits of an address of 0x0010_1004.

**Note:**

After the flash memory is lost, as this register is cleared when reset is issued in a chip, the stored CR trimming data is lost. Therefore, before this register is cleared, save the CR trimming data stored in the register on the RAM, etc.

## 2. WorkFlash Memory



This series is equipped with 64 KBytes to 128 KBytes of MainFlash memory and 32KBytes of WorkFlash memory.

This chapter gives an overview of, and explains the structure, operation, and registers of the WorkFlash memory. See “CHAPTER MainFlash Memory” for details of the MainFlash memory.

This series has built-in WorkFlash memory with a capacity of 32 KBytes that supports data erasing by all sectors, data erasing by unit of sector, and data writing by the CPU.

Contents described with “flash memory” are information for the WorkFlash memory in this chapter.

2.1 Overview

2.2 Configuration

2.3 Operating Description

2.4 Registers



## 2.1 Overview

This series is equipped with 32 KBytes of built-in WorkFlash memory. The built-in Workflash memory can be erased data of sector-by-sector, all-sector batch erased data, and programmed data in units of half-word (16-bit) by the Cortex-M3 CPU.

### WorkFlash Memory Features

- Usable capacity:  
32 Kbytes(8K bytes × 4 sectors)
  
- High-speed flash:  
Up to 40MHz: 0Wait
  
- Operating mode:
  1. CPU ROM mode  
This mode only allows reading of flash memory data. Word access is available. However, in this mode, it is not possible to activate the automatic algorithm<sup>\*1</sup> to perform writing or erasing.
  2. CPU programming mode  
This mode allows reading, writing, and erasing of flash memory (automatic algorithm<sup>\*1</sup>). Because word access is not available, programs that are contained in the flash memory cannot be executed while operating in this mode. Half-word access is available.
  3. ROM writer mode  
This mode allows reading, writing, and erasing of flash memory from a ROM writer (automatic algorithm<sup>\*1</sup>).
- Built-in flash security function  
(Prevents reading of the content of flash memory by a third party)  
See "CHAPTER Flash Security" for details on the flash security function.

### Note:

This document explains flash memory in the case where it is being used in CPU mode.

For details on accessing the flash memory from a ROM writer, see the instruction manual of the ROM writer that is being used.

\*1: Automatic algorithm=Embedded Algorithm

## 2.2 Configuration

This series consists of 32 Kbytes WorkFlash memory area, a security code area, and a High-Speed CR trimming data area.

Figure 2-1 shows the address and sector structure of the WorkFlash memory.

See "CHAPTER Flash Security" for details on the security.

Figure 2-1. Memory map of WorkFlash memory

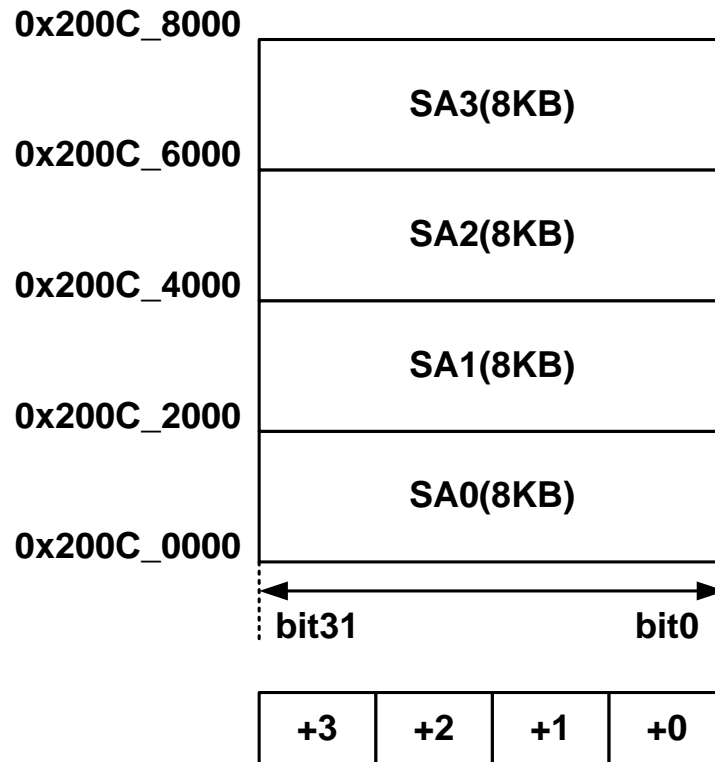

## 2.3 Operating Description

This section explains the WorkFlash memory operation.

2.3.1 WorkFlash Memory Access Modes

2.3.2 Automatic Algorithm

2.3.3 Explanation of WorkFlash Memory Operation

2.3.4 Cautions When Using WorkFlash Memory

### 2.3.1 WorkFlash Memory Access Modes

The following two access modes are available for accessing WorkFlash memory from the CPU.

- CPU ROM mode
- CPU programming mode

These modes can be selected by the WorkFlash access size bits (WFASZR: ASZ).

#### **CPU ROM Mode**

This mode only allows reading of flash memory data.

This mode is entered by setting the WorkFlash access size bits (WFASZR: ASZ) to "1" (32-bit read), and enables word access.

However, in this mode, it is not possible to execute commands, to activate the automatic algorithm or to write or erase data.

The flash memory always enters this mode after reset is released.

#### **CPU Programming Mode**

This mode allows reading, writing, and erasing of data.

This mode is entered by setting the WorkFlash access size bits (WFASZR: ASZ) to "0" (16-bit read/write), and enables flash programming.

Because word access is not possible in this mode, programs that are contained in the flash memory cannot be executed. The operation while in this mode is as follows.

- During reading
  - Flash memory is accessed in half-word, with data read out in blocks of 16 bits.
- During writing commands
  - The automatic algorithm can be activated to write or erase data. See Section "1.3.2 Automatic Algorithm" for details on the automatic algorithm.

Table 2-1. Access Modes of Flash memory

Access Mode	Access Size	Automatic Algorithm	Instruction execution in the Flash Memory
CPU ROM mode	32bit	disable	enable
CPU programming mode	16bit	enable	Prohibited

#### **Note:**

The flash memory is always set to CPU ROM mode when a reset is released. Therefore, if a reset occurs after entering CPU programming mode, the WorkFlash access size bits (WFASZR: ASZ) are set to "1" and the flash memory returns to CPU ROM mode.

## 2.3.2 Automatic Algorithm

When CPU programming mode is used, writing to and erasing WorkFlash memory is performed by activating the automatic algorithm.

This section explains the automatic algorithm.

### 2.3.2.1 Command Sequences

#### 2.3.2.2 Command Operating Explanations

#### 2.3.2.3 Automatic Algorithm Run States

### 2.3.2.1 Command Sequences

The automatic algorithm is activated by sequentially writing half-word (16-bit) data to the WorkFlash memory one to six times in a row. This is called a command. Table 2-2 shows the command sequences.

Table 2-2. Command sequence chart

Command	Number of writes	1st write		2nd write		3rd write		4th write		5th write		6th write	
		Address	Data	Address	Data	Address	Data	Address	Data	Address	Data	Address	Data
Read/Reset	1	0xXXX	0xF0	--	--	--	--	--	--	--	--	--	--
Write	4	0xAA8	0xAA	0x554	0x55	0xAA8	0xA0	PA	PD	--	--	--	--
Flash erase	6	0xAA8	0xAA	0x554	0x55	0xAA8	0x80	0xAA8	0xAA	0x554	0x55	0xAA8	0x10
Sector erase	6	0xAA8	0xAA	0x554	0x55	0xAA8	0x80	0xAA8	0xAA	0x554	0x55	SA	0x30
Sector erase suspended	1	0xXXX	0xB0	--	--	--	--	--	--	--	--	--	--
Sector erase restarting	1	0xXXX	0x30	--	--	--	--	--	--	--	--	--	--

X: Any value

PA: Write address

SA: Sector address (Specify any address within the address range of the sector to erase)

PD: Write data

#### Notes:

- The data notation in Table 2-2 only shows the lower 8 bits. The upper 8 bits can be set to any value.
- Write commands as half-word at any time.
- The address notation in Table 2-2 only shows the lower 16 bits. The upper 16 bits should be set to any address within the address range of the target flash memory. When the address outside the flash address range is specified, the command sequence would not move correctly since the flash memory cannot recognize the command.

### 2.3.2.2 Command Operating Explanations

This section explains the command operating.

#### **Read/Reset Command**

The flash memory can be read and reset by sending the read/reset command to the target sector in sequence.

When a read/reset command is issued, the flash memory maintains the read state until another command is issued.

When the execution of the automatic algorithm exceeds the time limit, the flash memory is returned to the read/reset state by issuing the read/reset command.

See Section "1.3.3.1 Read/Reset Operation" for details on the actual operation.

#### **Program (Write) Command**

The automatic algorithm can be activated and the data is written to the flash memory by issuing the write command to the target sector in four consecutive writes. Data writes can be performed in any order of addresses, and may also cross sector boundaries.

In CPU programming mode, data is written in half-word.

Once the forth command issuance has finished, the automatic algorithm is activated and the automatic write to the flash memory starts. After executing the automatic write algorithm command sequence, there is no need to control the flash memory externally.

See Section "1.3.3.2 Write Operation" for details on the actual operation.

#### **Notes:**

- The command is not recognized properly if the fourth write command (write data cycle) is issued to an odd address. Always issue it to an even address.
- Only a single half-word of data can be written for each write command sequence.  
To write multiple pieces of data, issue one write command sequence for each piece of data.

#### **Flash Erase Command**

All of the sectors in flash memory can be batch-erased by sending the flash erase command to the target sector in six consecutive writes. Once the sixth sequential write has finished, the automatic algorithm is activated and the flash erase operation starts.

#### **Sector Erase Command**

A single sector of flash memory can be erased by sending the sector erase command to the target sector in six consecutive writes. Once the sixth sequential write has finished and 35  $\mu$ s has elapsed (timeout interval), the automatic algorithm is activated and the sector erase operation begins.

To erase multiple sectors, issue the sector erase code (0x30) which is the sixth write code of the sector erase command to the address of the sector to erase within 35  $\mu$ s (timeout interval). If the sector erase code is not issued within the timeout interval, the sector erase code added after the timeout interval has elapsed may become inactive.

#### **Sector Erase Suspended Command**

By issuing the sector erase suspended command during sector erase or during command timeout, sector erase can be suspended. In the sector erase suspended state, the read operation of memory cells of the sector not to erase is made possible.

See Section "1.3.3.5 Sector Erase Suspended Operation" for details on the actual operation.

#### **Note:**

This command is only valid during sector erase. It is ignored even if it is issued during flash erase or during write.

### Sector Erase Restart Command

In order to restart the erase operation in the sector erase suspended state, issue the sector erase restart command. Issuing the sector erase restart command returns the flash memory to the sector erase state and restarts the erase operation.

See Section "1.3.3.6 Sector Erase Restart Operation" for details on the actual operation.

**Note:**

This command is only valid during sector erase suspended. It is ignored even if it is issued during sector erase.

### 2.3.2.3 Automatic Algorithm Run States

Because writing and erasing of WorkFlash memory is performed by the automatic algorithm, whether or not the automatic algorithm is currently executing can be checked using the WorkFlash ready bit (WFSTR: RDY) and the operating status can be checked using the hardware sequence flags.

**Hardware Sequence Flags**

These flags indicate the status of the automatic algorithm. When the WorkFlash ready bit (WFSTR: RDY) is "0", the operating status can be checked by reading any address in flash memory.

Figure 2-2 shows the bit structure of the hardware sequence flags.

Figure 2-2. Bit structure of the hardware sequence flags

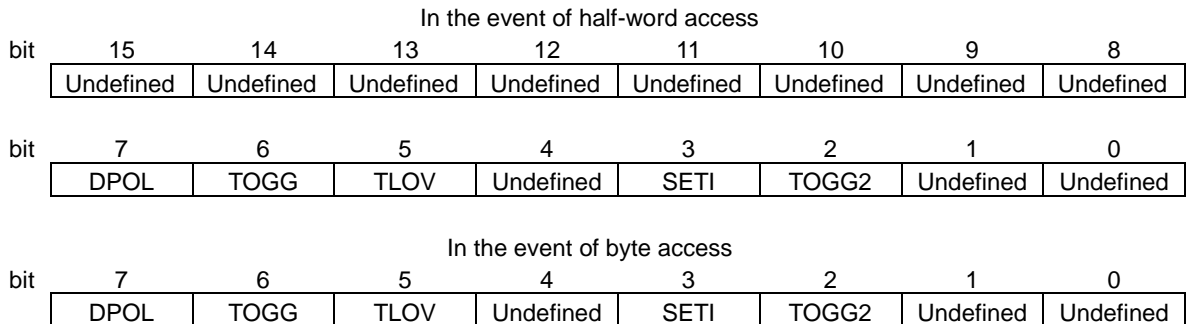

**Notes:**

- These flags cannot be read using word access. When in CPU programming mode, always read using half-word or byte access.
- In CPU ROM mode, the hardware sequence flags cannot be read no matter which address is read.
- Because the correct value might not be read out immediately after issuing a command, ignore the first value of the hardware sequence flags that is read after issuing a command

**Status of each bit and WorkFlash memory**

Table 2-3 shows the correspondence between each bit of the hardware sequence flags and the status of the flash memory.

Table 2-3. List of hardware sequence flag states

State		DPOL	TOGG	TLOV	SETI	TOGG2		
Running	Automatic write operation		Inverted data (*1)	Toggle	0	0	0	
	Automatic Erase operation	Flash erase		0	Toggle	0	1	Toggle
		Sector erase	timeout interval	0	Toggle	0	0	Toggle
			erase	0	Toggle	0	1	Toggle
		Sector erase suspended	Read (Sector to erase)		0	0	0	1
Read (Sector not to erase)			Data (*1)	Data (*1)	Data (*1)	Data (*1)	Data (*1)	
Time limit exceeded	Write operation		Inverted data (*1)	Toggle	1	0	0	
	Sector/Flash erase		0	Toggle	1	1	Toggle	

\*1 See " Bit Descriptions" for the values that can be read.

**Bit Descriptions**

[bit15:8] Undefined bits

**[bit7] DPOL: Data polling flag bit**

When the hardware sequence flags are read, by specifying an arbitrary address, this bit uses a data polling function to indicate whether or not the automatic algorithm is currently running.

The value that is read out varies depending on the operating state.

- During writing
  - While write is in progress:
    - Reads out the opposite value (inverse data) of bit 7 of data written at the last command sequence (PD). This does not access the address that was specified for reading the hardware sequence flags.
  - After write finishes:
    - Reads out the value of bit 7 of the address specified for reading the hardware sequence flags.
- During sector erase
  - While sector erase is executing:
    - Reads out "0" from all areas of flash memory.
  - After sector erase finishes:
    - Always reads out "1".

- During flash erase
  - While flash erase is executing: Always reads out "0".
  - After flash erase: Always reads out "1".
- During sector erase suspended
  - When this bit is read out by specifying an address in the sector specified as sector erase:  
Reads out "0".
  - When this bit is read out by specifying an address in the sector other than specified as sector erase:  
Reads out the value of bit 7 of a specified address.

**Note:**

The data for a specified address cannot be read while the automatic algorithm is running. Confirm that the automatic algorithm has finished running by using this bit before reading data.

**[bit6] TOGG: Toggle Flag Bit**

When the hardware sequence flags are read by specifying an arbitrary address, this bit indicates whether or not the automatic algorithm is currently running.

The value that is read out varies depending on the operating state.

- During write, sector erase, or flash erase
  - While write, sector erase, or flash erase is in progress:  
When this bit is read out continuously, it alternately returns "1" and "0" (toggles). The address that was specified for reading the hardware sequence flags is not accessed.
  - After write, sector erase, or flash erase has finished:  
Reads out the value of bit 6 of the address specified for reading the hardware sequence flags.
- During sector erase suspended
  - When this bit is read out by specifying an address in the sector specified as sector erase:  
Reads out "0".
  - When this bit is read out by specifying an address in the sector other than specified as sector erase:  
Reads out the value of bit 6 of a specified address.

**[bit5] TLOV: Timing Limit Exceeded Flag Bit**

When the hardware sequence flags are read by specifying an arbitrary address, this bit indicates whether or not the execution time of the automatic algorithm has exceeded the rated time defined internally within the flash memory (number of internal pulses).

The value that is read out varies depending on the operating state.

- During write, sector erase, or flash erase

The following values are read out.

0: Within the rated time  
1: Rated time exceeded

When this bit is "1", if the DPOL bit and TOGG bit indicate that the automatic algorithm is currently executing, that means a failure occurred during the write or erase.

For example, because data that has been written to "0" cannot be overwritten to "1" in flash memory, if "1" is written to an address that has been written to "0", the flash memory is locked and the automatic algorithm does not finish. In this case, the value of the DPOL bit remains invalid, and "1" and "0" are continuously read out alternately from the TOGG bit.



Once the rated time is exceeded while still in this state, this bit changes to "1". If this bit changes to "1", issue the reset command.

- During sector erase suspended
  - When this bit is read out by specifying an address in the sector specified as sector erase:  
Reads out "0".
  - When this bit is read out by specifying an address in the sector other than specified as sector erase:  
Reads out the value of bit 5 of a specified address.

**Note:**

If this bit is "1", it indicates that the flash memory was not used correctly. This is not a malfunction of the flash memory.

Perform the appropriate processing after issuing the reset command.

**[bit4] Undefined bit****[bit3] SETI: Sector Erase Timer Flag Bit**

When a sector is erased, a timeout interval of 35  $\mu$ s is required from when the sector erase command is issued until the sector erase actually begins.

When the hardware sequence flags are read by specifying an arbitrary address, this bit indicates whether or not the flash memory is currently in the sector erase command timeout interval.

The value that is read out varies depending on the operating state.

- During sector erase:

When sectors are being erasing, it can be checked whether or not the following sector erase code can be accepted by checking this bit before inputting the following sector erase code.

The following values are read out without accessing the address specified in order to read the hardware sequence flags.

0: Within sector erase timeout interval

The following sector erase code (0x30) can be accepted.

1: Sector erase timeout interval exceeded

In this case, if the DPOL bit and TOGG bit indicate that the automatic algorithm is currently executing, the erase operation has started internally within the flash memory. In this case, commands other than the sector erase suspended (0xB0) are ignored until the internal flash memory erase operation has finished.

- During sector erase suspended
  - When this bit is read out by specifying an address in the sector specified as sector erase:  
Reads out "1".
  - When this bit is read out by specifying an address in the sector other than specified as sector erase:  
Reads out the value of bit 3 of a specified address.

**[bit2] TOGG2 : Toggle flag bit**

In the sector erase suspended state, a sector which is not the erase target can be read. However, the erase target sector cannot be read. This toggle bit flag can detect whether the corresponding sector is the erase target sector during the sector erase suspend by checking the toggle operation of the read data.

- During writing  
Reads out "0".
- During sector erase or flash erase  
When this bit is read out continuously, "1" and "0" are alternately read (toggle operation).
- During sector erase suspended
  - When this bit is read out by specifying an address in the sector specified as sector erase:  
When this bit is read out continuously, "1" and "0" are alternately read (toggle operation)
  - When this bit is read out by specifying an address in the sector other than specified as sector erase:  
Reads out the value of bit 2 of a specified address.

**[bit1:0] Undefined bits**

### 2.3.3 Explanation of WorkFlash Memory Operation

The operation of the WorkFlash memory is explained for each command.

#### 2.3.3.1 Read/Reset Operation

#### 2.3.3.2 Write Operation

#### 2.3.3.3 Flash Erase Operation

#### 2.3.3.4 Sector Erase Operation

#### 2.3.3.5 Sector Erase Suspended Operation

#### 2.3.3.6 Sector Erase Restart Operation

#### 2.3.3.1 *Read/Reset Operation*

This section explains the read/reset operation.

To place the flash memory in the read/reset state, send read/reset commands to the target sector consecutively.

Because the read/reset state is the default state of the flash memory, the flash memory always returns to this state when the power is turned on or when a command finishes successfully. When the power is turned on, there is no need to issue a data read command. Furthermore, because data can be read by normal read access and programs can be accessed by the CPU while in the read/reset state, there is no need to issue read/reset commands.

#### 2.3.3.2 *Write Operation*

This section explains the write operation.

Writes are performed according to the following procedure.

1. The write command is issued to the target sector sequentially  
The automatic algorithm activates and the data is written to the flash memory.  
After the write command is issued, there is no need to control the flash memory externally.
2. Perform read access on the address that was written  
The data that is read is the hardware sequence flags. Therefore, once bit 7 (the DPOL bit) of the read data matches the value that was written, the write to the flash memory has finished. If the write has not finished, the reverse value (inverted data) of bit 7 written at the last command sequence (PD) is read out.

Figure 2-3 shows an example of a write operation to the flash memory.

Figure 2-3. Example Write Operation

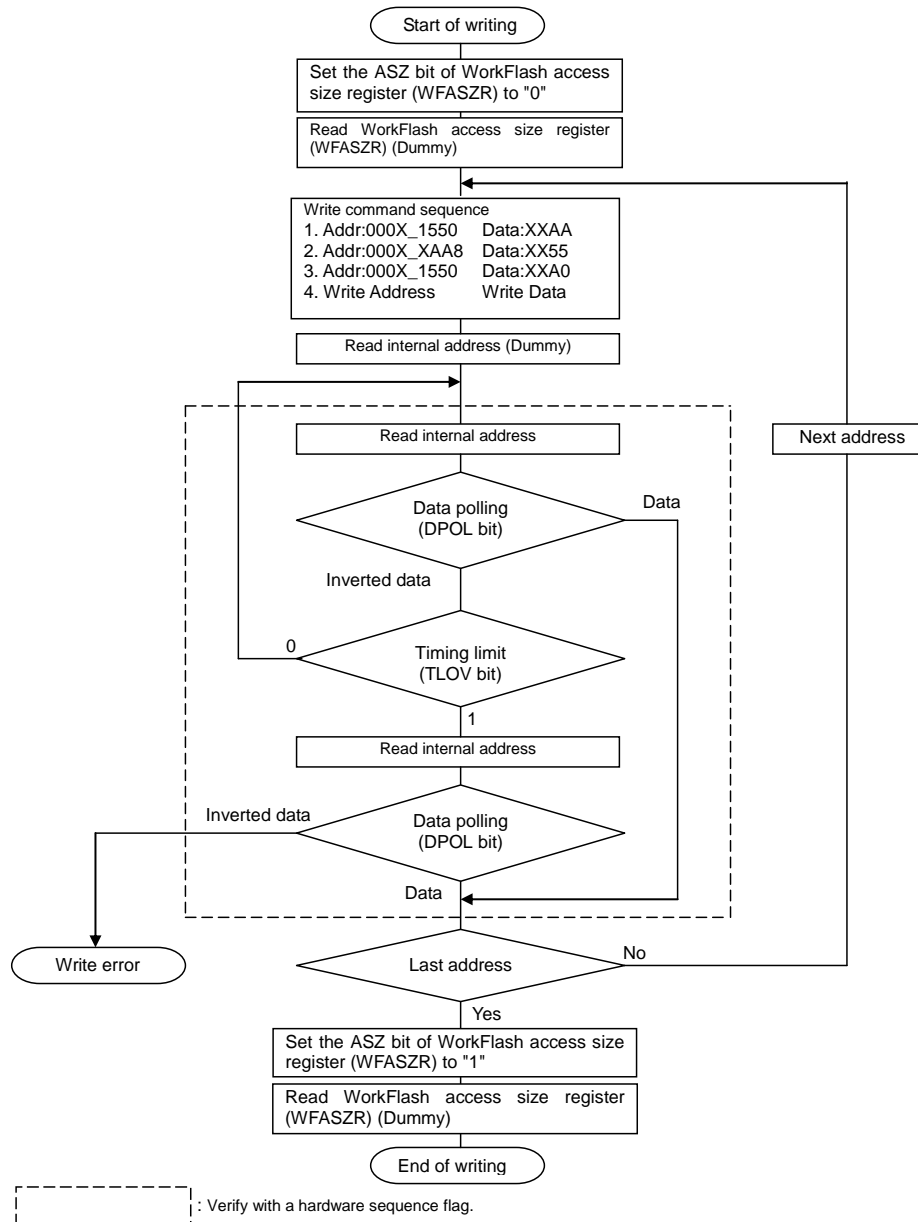

**Notes:**

- See Section "1.3.2 Automatic Algorithm" for details on the write command.
- Because the value of the DPOL bit of the hardware sequence flags changes at the same time as the TLOV bit, the value needs to be checked again even if the TLOV bit is "1".
- The toggle operation stops at the same time as the TOGG bit and TLOV bit of the hardware sequence flags change to "1". Therefore, even if the TLOV bit is "1", the TOGG bit needs to be checked again.
- Although the flash memory can be written in any sequence of addresses regardless of crossing sector boundaries, only a single half-word of data can be written with each write command sequence. To write multiple pieces of data, issue one write command sequence for each piece of data.
- All commands issued to the flash memory during the write operation are ignored.

- If the device is reset while the write is in progress, the data that is written is not guaranteed.

### 2.3.3.3 *Flash Erase Operation*

This section explains the flash erase operation.

All sectors in flash memory can be erased in one batch. Erasing all of the sectors in one batch is called flash erase.

The automatic algorithm can be activated and all of the sectors can be erased in one batch by sending the flash erase command sequentially to the target sector.

See Section "1.3.2 Automatic Algorithm" for details on the flash erase command.

1. Issue the flash erase command sequentially to the target sector

The automatic algorithm is activated and the flash erase operation of the flash memory begins.

2. Perform read access to an arbitrary address

The data that is read is the hardware sequence flag. Therefore, if the value of bit 7 (the DPOL bit) of the data that was read is "1", that means t the flash erase has finished.

The time required to erase the flash is "sector erase time x total number of sectors + flash write time (preprogramming)".

Once the flash erase operation has finished, the flash memory returns to read/reset mode.

### 2.3.3.4 *Sector Erase Operation*

This section explains the sector erase operation.

Sectors in the flash memory can be selected and the data of only the selected sectors can be erased. Multiple sectors can be specified at the same time.

Sectors are erased according to the following sequence.

1. Issue the sector erase command sequentially to the target sector

Once 35  $\mu$ s has elapsed (the timeout interval), the automatic algorithm activates and the sector erase operation begins.

To erase multiple sectors, issue the erase code (0x30) to an address in the sector to erase within 35  $\mu$ s (the timeout interval). If the code is issued after the timeout interval has elapsed, the added sector erase code may be invalid.

2. Perform read access to an arbitrary address

The data that is read is the hardware sequence flags. Therefore, if the value of bit 7 (the DPOL bit) of the data that was read is "1", that means the sector erase has finished.

Furthermore, it can be checked whether or not the sector erase has finished by using the TOGG bit. Figure 2-4 shows an example of the sector erase procedure for the case of using the TOGG bit for confirmation.

Figure 2-4. Example Sector Erase Procedure

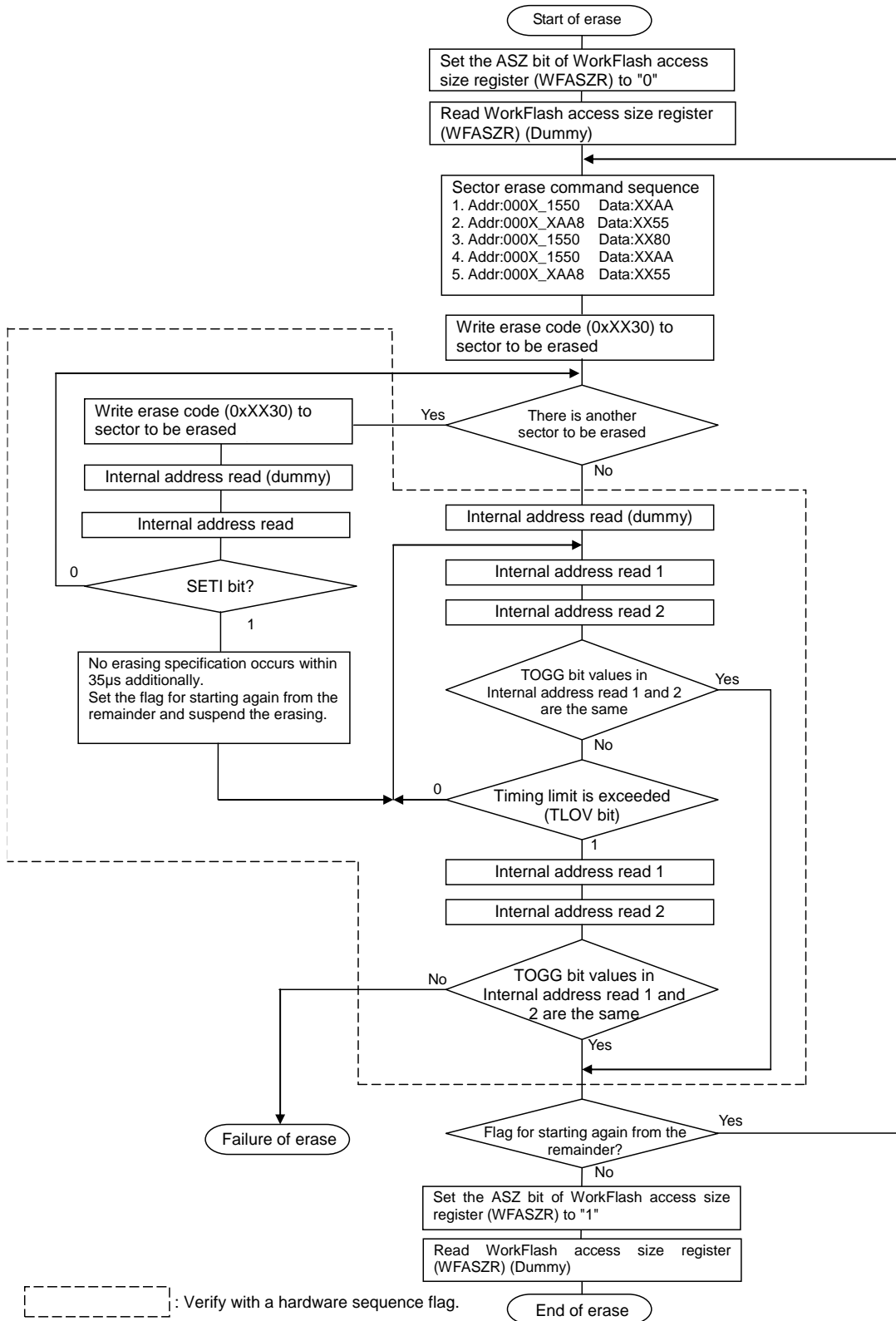

The time required to erase a sector is "(sector erase time + sector write time (preprogramming)) × number of sectors".

Once the sector erase operation has finished, the flash memory returns to read/reset mode.

**Notes:**

- See Section "1.3.2 Automatic Algorithm" for details on the sector erase command.
- Because the value of the DPOL bit of the hardware sequence flags changes at the same time as the TLOV bit, the value needs to be checked again even if the TLOV bit is "1".
- The toggle operation stops at the same time as the TOGG bit and TLOV bit of the hardware sequence flags change to "1". Therefore, even if the TLOV bit is "1", the TOGG bit needs to be checked again.
- If a command other than the sector erase command or the erase suspended command is issued during sector erase, including the timeout interval, it is ignored.

### 2.3.3.5 *Sector Erase Suspended Operation*

This section explains the sector erase suspended operation.

When the sector erase suspended command is sent during sector erase or in the command timeout state, the flash memory makes a transition to the sector erase suspended state and temporarily suspends the erase operation.

By sending the erase restart command, the flash memory is returned to the sector erase state and can restart the suspended erase operation. However, even if the flash memory has changed from the command timeout state to the sector erase suspended state, when the erase restart command is written properly, the flash memory does not make a transition to the command timeout state but make a transition to the sector erase state and restarts the sector erase operation immediately.

#### **Sector Erase Suspended Operation**

Sector erase is suspended in the following steps:

1. Write the sector erase suspended command to an arbitrary address within the address range of the flash memory during the time between the command timeout interval and the sector erase interval.
2. If the sector erase suspended command is issued during the command timeout interval, stop timeout immediately and suspend the erase operation. If the sector erase suspended command is issued during sector erase, it takes up to 35  $\mu$ s until erasing is actually stopped.

**Notes:**

- See Section "1.3.2 Automatic Algorithm" for details on the sector erase suspended command.
- Sector erase can only be suspended during the time between the command timeout interval and the sector erase interval. Flash erase cannot be suspended. In addition, even if the sector erase suspended command is issued again during sector erase suspended, it is ignored.

#### **State after Sector Erase Suspended**

If a sector to erase is read out after sector erase suspended, the hardware sequence flag is read out. On the other hand, if a sector not to erase is read out, data of a memory cell is read out.

**Note:**

New write and erase commands are ignored in the sector erase suspended state.

### 2.3.3.6 Sector Erase Restart Operation

This section explains the operation for restarting sector erase during sector erase suspended.

When the sector erase restart command is issued to an arbitrary address while sector erase is suspended, sector erase can be restarted.

When the sector erase restart command is issued, the sector erase operation during sector erase suspended is restarted.

See Section "1.3.2 Automatic Algorithm" for details on the sector erase restart command.

#### Notes:

- The sector erase restart command is only valid during sector erase suspended. Even if the sector erase restart command is issued during sector erase, it is ignored.
- After the sector erase restart command is issued, it takes more than 2ms until the sector erase operation is restarted. Therefore, when erase restart and erase stop are repeated at intervals less than this time, timing limit is exceeded while no erase operation is in progress. If the sector erase suspended command is to be issued again after the sector erase restart command is issued, leave an interval more than 2ms after the sector erase restart command is issued.

### 2.3.4 Cautions When Using WorkFlash Memory

This section explains the cautions when using WorkFlash memory.

- If this device is reset during the write, the data that is written cannot be guaranteed. Moreover, It is necessary to prevent an unexpected reset like Watchdog Timer from occurring during the writing and deleting.
- If the CPU programming mode is configured (ASZ=0) in the ASZ bits of the WorkFlash access size register (WFASZR), do not execute any programs in the flash memory. The correct values will not be retrieved and the program will run out of control.
- If the CPU programming mode is configured (ASZ=0) in the ASZ bits of the WorkFlash access size register (WFASZR) and the interrupt vector table is in the flash memory, ensure that no interrupt requests occur. The correct values will not be retrieved and the program will run out of control.
- If the CPU programming mode is configured (ASZ=0) in the ASZ bits of the WorkFlash access size register (WFASZR), do not transition to low power consumption mode.
- If the CPU ROM mode is configured (ASZ=1) in the ASZ bits of the WorkFlash access size register (WFASZR), do not write to the flash memory.
- If the CPU programming mode is configured (ASZ=0) in the ASZ bits of the WorkFlash access size register (WFASZR), always write to the flash memory in half-word. Do not write in bytes.
- Immediately after issuing the automatic algorithm command to the flash memory, always perform a dummy read before reading the data that is actually wanted. If data is read immediately after issuing the automatic algorithm command, the read value cannot be guaranteed.
- If the device is forced to transit to the low power consumption mode, ensure the operations of the flash memory automatic algorithm is completed.  
See "CHAPTER Low Power Consumption Mode" of the "FM3 Peripheral Manual" for details on the low power consumption mode.

## 2.4 Registers

This section explains the registers.

Table 2-4. List of Registers

Abbreviated Register Name	Register Name	Reference
WFASZR	WorkFlash Access Size Register	2.4.1
WFRWTR	WorkFlash Read Wait Register	2.4.2
WFSTR	WorkFlash Status Register	2.4.3

### 2.4.1 WFASZR (WorkFlash Access Size Register)

This section explains the WFASZR.

This register configures the access size for flash memory. After reset is released, ASZ is set to "1" (32-bit read), and the flash memory enters CPU ROM mode. To put the flash memory into CPU programming mode, set ASZ to "0".

Bit	7	6	5	4	3	2	1	0
Field	Reserved							ASZ
Attribute								RW
Initial value								1

Field	bit	Description
ASZ	0	WorkFlash Access Size Specifies the access size of the flash memory. 0 : 16-bit read/write (CPU programming mode) 1 : 32-bit read (CPU ROM mode: Initial value)

**Notes:**

- When ASZ is set to "01", always perform writes to flash using half-word access (16-bit access).
- Do not change this register using an instruction that is contained in the flash memory. Overwrite this register from a program in any other area except for flash memory.
- Perform a dummy read to register, after changing this register.



### 2.4.2 WFRWTR (WorkFlash Read Wait Register)

This section explains the WFRWTR.

This register is meaningful when ASZ="1" (32-bit read mode).  
It configures the access method for flash memory.

bit	7	6	5	4	3	2	1	0
Field	Reserved					RWT		
Attribute						RW	RW	RW
Initial value						0	0	0

Field	Bit	Description
RWT	2:0	Read Wait Cycle Specifies the access method for flash memory. 000 : 0 cycle wait mode (Initial value) This setting can be used when HCLK is 40 MHz or less. 001 : 2 cycles wait mode This setting can be used when HCLK is over 40 MHz. 01x : Setting prohibited 1xx : Setting prohibited

**Notes:**

- Do not set RWT to "000"(0 cycle wait mode) if HCLK exceeds 40 MHz.
- During RWT setting is 000, HCLK must not exceed 40MHz.
- Perform a dummy read to register, after changing this register.

### 2.4.3 WFSTR (WorkFlash Status Register)

This section explains the WFSTR.

This is a status register of flash memory.

bit	7	6	5	4	3	2	1	0
Field	Reserved						HNG	RDY
Attribute							R	R
Initial value							0	X

#### [bit7:2] Reserved bits

The read values are undefined. Ignored on write.

#### [bit1] HNG: WorkFlash Hang

Indicates whether the flash memory is in the HANG state. Flash memory enters the HANG state if the timing is exceeded (See "[bit5] TLOV: Timing Limit Exceeded Flag Bit"). If this bit becomes "1", issue a reset command (See Section "1.3.2.1 Command Sequences").

Because the correct value might not be read out immediately after issuing an automatic algorithm command, ignore the value of this bit as read out the first time after a command is issued.

Field	bit	Description
HNG	1	WorkFlash Hang 0 : The flash memory HANG state has not been detected. 1 : The flash memory HANG state has been detected.

#### [bit0] RDY: WorkFlash Rdy

Indicates whether a flash memory writes or erases operation using the automatic algorithm is in progress or finished. While an operation is in progress, data cannot be written and the flash memory cannot be erased.

Field	bit	Description
RDY	0	WorkFlash Rdy 0 : Operation in progress (cannot write or erase) 1 : Operation finished (can write or erase)

Because the correct value might not be read immediately after an automatic algorithm command is issued, ignore the value of this bit as read the first time after a command is issued

# 3. Flash Security



The flash security function protects contents of the MainFlash memory and the WorkFlash memory. This section describes the overview and operations of the flash security.

3.1 Overview

3.2 Operation Explanation

## 3.1 Overview

This section explains the overview of the flash security.

If the protection code of 0x0001 is written in the security code area of MainFlash memory, access to the MainFlash memory and the WorkFlash memory is restricted. Once these flash memories are protected, performing the flash erase operation only can unlock the function otherwise read/write access to the MainFlash memory and the WorkFlash memory from any external pins is not possible.

This function is suitable for applications requiring security of self-containing program and data stored in the flash memory.

Table 3-1 shows the address and the protection code of the security code.

Table 3-1. Address of security code and protection code

Address	Protection Code
0x0010_0000	0x0001

**Note:**

When the protection code is written in the security code area of the MainFlash memory, the flash security will be valid for both of the MainFlash memory and the WorkFlash memory at the same time.

## 3.2 Operation Explanation

This section explains the operation of the flash security.

### Setting Security

Write the protection code 0x0001 in address of the security code. The security is enabled and set after all the reset factors are generated or after turning on the power again.

### Releasing Security

1. Issue the flash erase command to the WorkFlash memory
2. Confirm if the flash erase operation for the WorkFlash memory is completed.
3. Issue the flash erase command to the MainFlash memory where the security code is stored.
4. The security is released by all the reset factors or power-on after the execution of flash erase.

### Operation with Security Enabled

The operations with security enabled vary depending on each mode.

Table 3-2 shows the security operations in each mode.

Table 3-2. Flash Operation with Security Enabled

Mode	Mode pin MD[1:0]	Access to flash			Access from JTAG pins
		Flash erase	Other commands	Read	
User mode	"00"	Enabled	Enabled	Valid data	Disabled
Serial writer mode	"01"	Enabled	Disabled	Invalid data	Disabled

### Notes:

- Writing the protection code is generally recommended to take place at the end of the flash programming. This is to avoid unnecessary protection during the programming.
- In user mode, there is no limit to flash memory even during security is enabled. However, JTAG pins are fixed not to access internally from these pins during security is enabled. To release security, perform the flash erase operation using a serial writer because the security cannot be released through JTAG pins.
- When security enabled, the obstruction analysis of the flash memory cannot be performed.
- When the security is released, erase the data of WorkFlash memory at first. The data of MainFlash memory cannot be erased before erasing the data of WorkFlash memory

## 4. Serial Programming Connection



This series supports serial onboard write (Cypress Semiconductor standard) to flash memory. This chapter explains the basic configuration for serial write to flash memory by using the Cypress Semiconductor Serial Programmer.

### 4.1 Serial Programmer

## 4.1 Serial Programmer

Cypress Semiconductor Serial Programmer (software) is an onboard programming tool for all microcontrollers with built-in flash memory.

Two types of Serial Programmer are available according to the PC interface (RS-232C or USB) used. Choose the type according to your environment.

Onboard write is possible with the product which USB function is installed by connecting the PC and microcontroller directly without performing USB-serial conversion.

### 4.1.1 Basic Configuration

#### 4.1.2 Pins Used

### 4.1.1 Basic Configuration

This section explains the basic configuration.

#### Basic Configuration of CYPRESS SEMICONDUCTOR MCU Programmer (Clock Asynchronous Serial Write)

CYPRESS SEMICONDUCTOR MCU Programmer writes data, through clock asynchronous serial communication, to built-in flash memory of a microcontroller installed in the user system when the PC and the user system are connected through RS-232C cable.

Figure 4-1 shows the basic configuration of CYPRESS SEMICONDUCTOR MCU Programmer, and Table 4-1 lists the system configuration.

Figure 4-1. Basic Configuration of CYPRESS SEMICONDUCTOR MCU Programmer

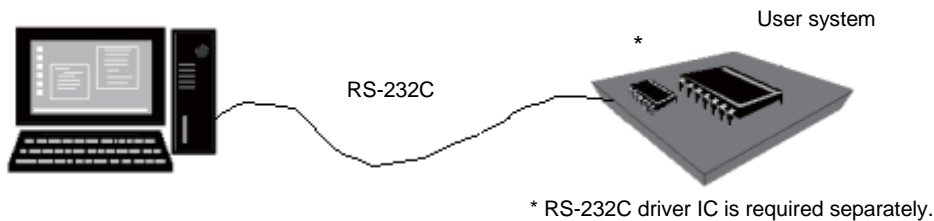

Table 4-1. System Configuration of CYPRESS SEMICONDUCTOR MCU Programmer

Name	Specifications
CYPRESS SEMICONDUCTOR MCU Programmer	Software (In case you request the data, contact to CYPRESS sales representatives.)
RS-232C cable	Sold on the market.

Figure 4-2. Connection Example using CYPRESS SEMICONDUCTOR MCU Programmer

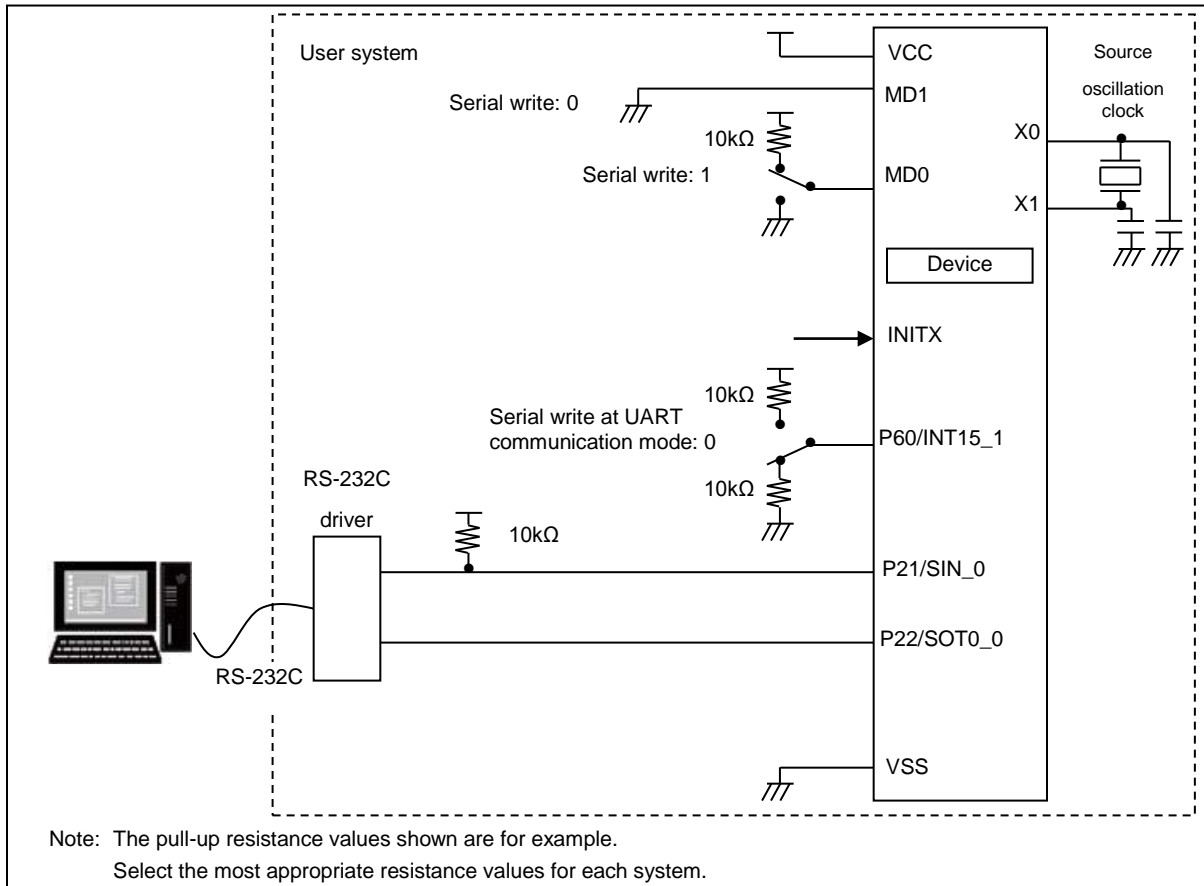

Table 4-2. Oscillating frequency and communication baud rate available for clock asynchronous serial communication

Source Oscillating Frequency	Communication Baud Rate
4MHz	9600bps
8MHz	19200bps
16MHz	38400bps
24MHz	57600bps
48MHz	115200bps

**Note:**

The serial write (UART communication mode) is available even if the source oscillation clock is not connected to the device. In this case, the communication baud rate is fixed at 9600bps.



**Basic Configuration of CYPRESS USB DIRECT Programmer (USB Serial Write)**

CYPRESS USB DIRECT Programmer writes data, through USB communication mode, to built-in flash memory of a microcontroller when the PC and the user system are connected through a USB cable.

Figure 4-3 shows the basic configuration of CYPRESS USB DIRECT Programmer, and Table 4-3 lists the system configuration.

Figure 4-3. Basic Configuration of CYPRESS USB DIRECT Programmer

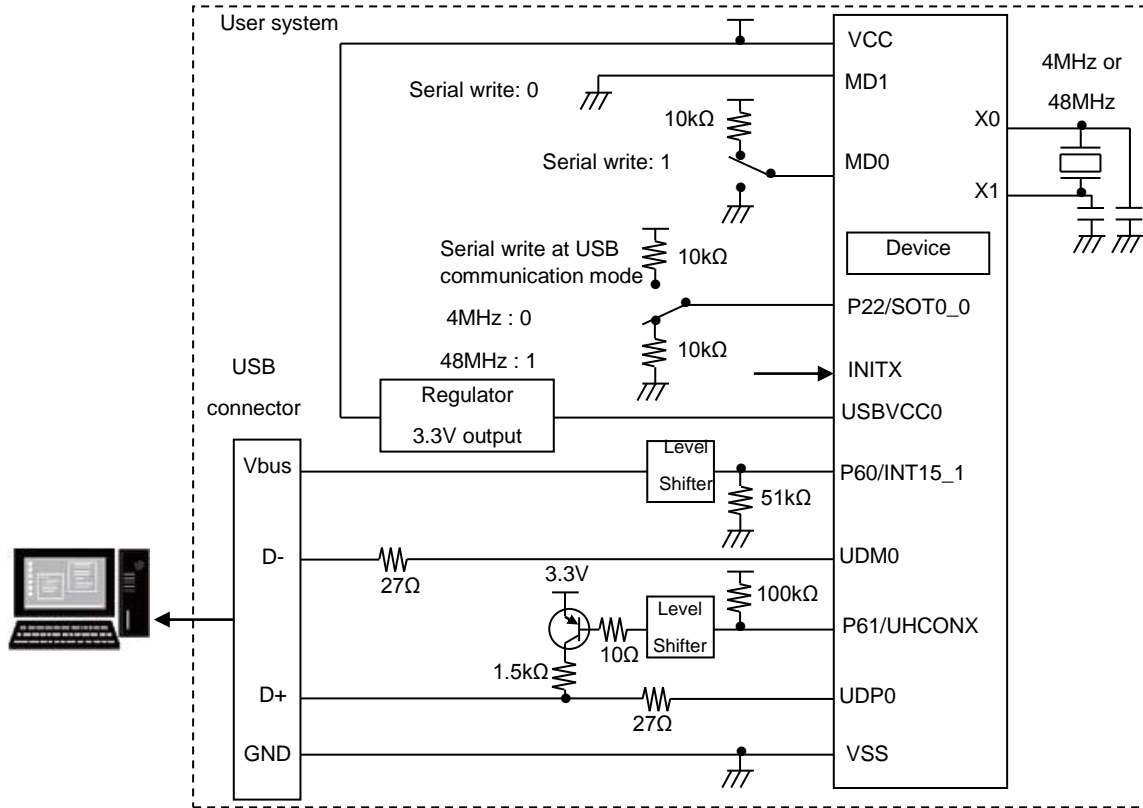

Table 4-3. System Configuration of CYPRESS USB DIRECT Programmer

Name	Specifications
CYPRESS USB DIRECT Programmer	Software (In case you request the data, contact to CYPRESS sales representatives.)
USB cable	Sold on the market.

For connection examples, see the manual (help section) of CYPRESS USB DIRECT Programmer.

Figure 4-4. Connection example using CYPRESS USB DIRECT Programmer (own power supply is used)



Note: The pull-up and pull-down resistance values shown are for example.  
 Select the most appropriate resistance values for each system.  
 Insert a level shifter for each system.

Figure 4-5. Connection example using CYPRESS USB DIRECT Programmer (bus power supply is used)

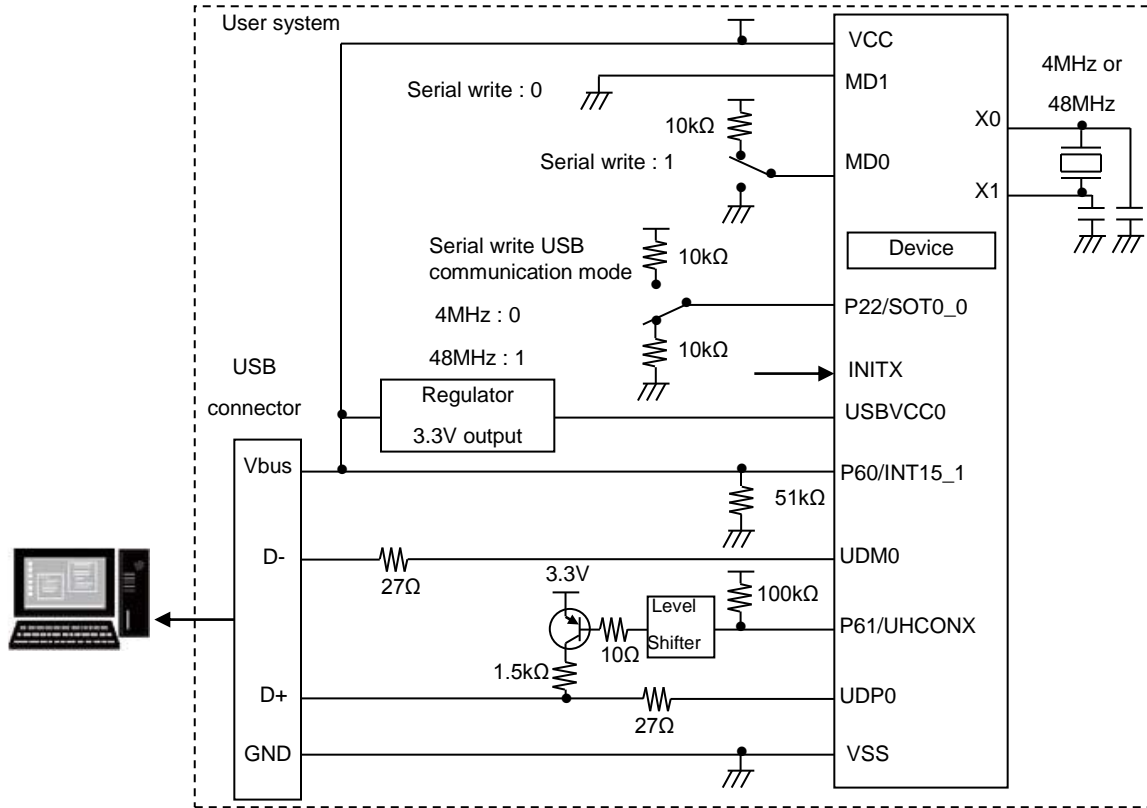

Note: The pull-up and pull-down resistance values shown are for example.  
Select the most appropriate resistance values for each system.

### 4.1.2 Pins Used

This section explains the used pins.

Table 4-4. Pins used for serial write

Pins	Function	Supplement
MD0, MD1	Mode pin	Performing an external reset or turning on the power after setting MD0=H and MD1=L enters the serial write mode. When attaching a pull-up or pull-down resistor, avoid long wiring.
X0, X1	Oscillation pin	See the "Data Sheet" for the source oscillation clock (main clock) frequencies that can be used in serial write mode. (Restrictions apply to clock asynchronous communication. For details, see Table 4-2.) In the UART communication mode, the serial write is available even if the main clock is not connected to the device.
P22/SOT0_0	UART serial data output pin/ USB source oscillating frequency select pin	When the communication mode is set to UART, this pin becomes a serial data output pin when communication begins after the serial write mode is activated. When the communication mode is set to USB, this pin controls the frequency for source oscillation clock. P22=L: source oscillation frequency: 4 MHz P22=H: source oscillation frequency: 48 MHz
P21/SIN0_0	Clock synchronous/ asynchronous select pin/UART serial data input pin	Setting the input level of this pin to "H" until the start of communication enables the clock asynchronous communication mode, and setting it to "L" enables the clock synchronous communication mode. When the communication mode is set to UART, this pin can be used as a serial data input pin when communication begins after the serial write mode is activated.
P60/INT15_1	Communication mode select pin	The communication mode is determined by the input level of this pin at reset to shift to the serial write mode. Setting this pin to "H" enables the USB communication mode, and setting it to "L" enables the UART communication mode.
P61/UHCONX	Pull-up control pin for UDPO	This pin controls the pull-up of USB side (D+) when the communication mode is USB. UHCONX=L : Connect the pull-up resistor UHCONX=H : Disconnect the pull-up resistor
UDPO	USB I/O pin	This pin becomes an input/output pin of USB side (D+) when the communication mode is set to USB.
UDM0	USB I/O pin	This pin becomes an input/output pin of USB side (D-) when the communication mode is set to USB.
INITX	Reset pin	-
VCC	Power supply pin	For writing, supply power to the microcontroller from the user system.
USBVCC0	Power supply pin for USB I/O	-
VSS	GND pin	-

# Revision History



## Document Revision History

Document Title: FM3 Family MB9A310K/110K Series , Flash Programming Guide

Document Number: 002-04787

Revision	Issue Date	Origin of Change	Description of Change
**	01/31/2012	TOYO	Initial release
*A	02/02/2016	TOYO	Migrated Spansion guide from MN706-00017-1v0-E -E to Cypress format
*B	07/28/2017	YSAT	Adapted Cypress new logo